

AUGUST 1972

# HEWLETT-PACKARD JOURNAL





# Compactness and Versatility in a New Plug-Together Digital Multimeter

*A new 4½ digit Multimeter is constructed in sections that plug together to form a compact instrument, giving the user a choice of capabilities.*

**By Albert Gookin**

**T**HE PHOTO below shows Hewlett-Packard's newest 4-digit voltmeter, the Model 3470 Measurement System.

This one was designed for bench and field use—in the design lab, the production department, the receiving department, the repair shop—wherever 1-mV resolution and 0.05% accuracy are needed. As such it is compact, and relatively inexpensive.

This one is versatile, however. It has sections that plug together to form a complete instrument (Fig. 3) in the same way as the Hewlett-Packard 5300 series counters<sup>1</sup>. The top section has a  $\pm 1$ -volt A-to-D converter, a 4½-digit display, power supplies for the whole instrument, and necessary control circuits. The bottom section has signal-conditioning circuits needed to convert the measured quantity into a dc voltage within the  $\pm 1$ -volt full-scale range.

The first signal-conditioning section to be designed is the Model 34702A Multimeter. When plugged onto the display section (Model 34740A), this section gives a digital multimeter that measures both dc and ac voltages in four full-scale ranges extending from 1 to 1000 volts and resistances in 6 full-scale ranges from 100  $\Omega$  to 10 M $\Omega$ . Also designed is a lower cost signal-conditioning

section (Model 34701A) that measures only dc in four ranges from 1 volt full-scale to 1000 volts. Future plug-on sections will include autoranging, high-sensitivity current measurements and other functional capabilities. For those who wish to design their own signal-conditioning circuits, an

empty bottom section is also available (outer shells are cast aluminum).

Center sections can be placed between the top and bottom sections to give additional capabilities. Initially these include a BCD module (Model 34721A) that converts the readout into binary-coded decimal format for driving printers or other data processing equipment, and a rechargeable battery module (Model 34720A) that provides more than six hours of line-independent operation (the instrument uses only 5 watts).

With the 34702A Multimeter plug-on section, the instrument has an accuracy for dc voltages that is 0.04% at full scale. AC accuracy is 0.3% from 45 Hz to 20 kHz, and 0.8% at 100 kHz. Ohms accuracy is 0.1%. The instrument reads to 100% above full scale with full accuracy on all ranges and functions, except the 1000-volt range where the maximum is 1200 volts.



**Fig. 1.** Model 3470 Measurement System.





**Fig. 2.** Model 3470 Measurement System consists of display section and various signal-conditioning sections (two at time of writing) plus battery and BCD output sections which fit together in combinations to suit differing users' needs.

### What's Inside

In making many of the design decisions that arose during the development phase, priority was assigned to keeping the design simple. In line with this philosophy, the display section's analog-to-digital converter is based on the widely-used dual-slope technique, a technique that has been proven in use and one that uses available IC's advantageously.

Briefly, the dual-slope technique derives a digital

measure of an unknown voltage by using the unknown to charge a capacitor in an integrator circuit during a fixed time interval, then counting clock pulses during the time a known voltage discharges the capacitor, as shown in Fig. 4.

At the start of each measurement cycle, switch S1 (Fig. 4) connects the unknown voltage to the integrator by way of the buffer amplifier, starting the charge of capacitor C1 while a data accumulator (Fig. 5) counts clock pulses.

When a predetermined number of clock pulses has been counted, the control circuits open switch S1 and close switch S2 (or S3), connecting the integrator to a known voltage of polarity opposite to the unknown. Capacitor C1 now discharges while a new series of clock pulses is counted. When the integrator output falls back to zero, the control circuits stop the clock count.

Because the discharge rate (down-ramp slope) is fixed by the reference voltage  $V_r$ , the capacitor discharge time ( $T_2$ ) is determined by the charge acquired while the unknown was connected. This is proportional to the unknown ( $V_{in}$ ) since the charge time ( $T_1$ ) is fixed. By making the charge time equal



**Cover:** The instrument shown here is the new Model 3490A Digital Multimeter, one of several instruments for digital measurement discussed in this issue. These range from a portable bench instrument (page 2) to plug-in cards used in a systems approach to measurement (page 13).

**In this issue:**

*Compactness and Versatility in a New Plug-Together Digital Multimeter*, by Albert Gookin ..... **page 2**

*A New Five-Digit Multimeter That Can Test Itself*, by Lee Thompson ..... **page 7**

*Functional Modularity Helps Designer and User of New Measurement and Control Subsystem*, by James M. Kasson ..... **page 13**

*Multiprogrammer Magnifies Minicomputer I/O Capacity*, by John Mickowski ..... **page 20**

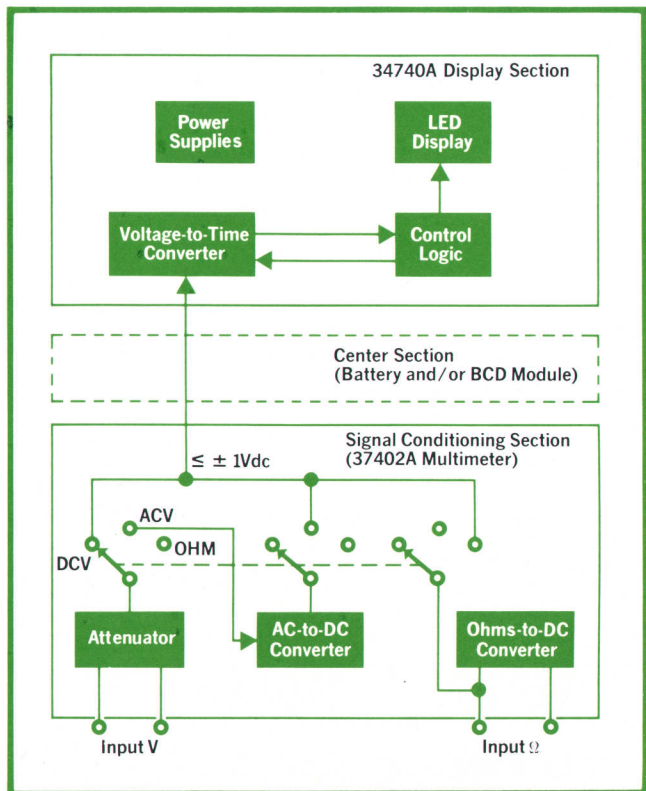

**Fig. 3.** Sections combine functions to form complete instrument, as shown by this skeleton block diagram. Signal conditioner in this combination is Model 37402A Multimeter section.



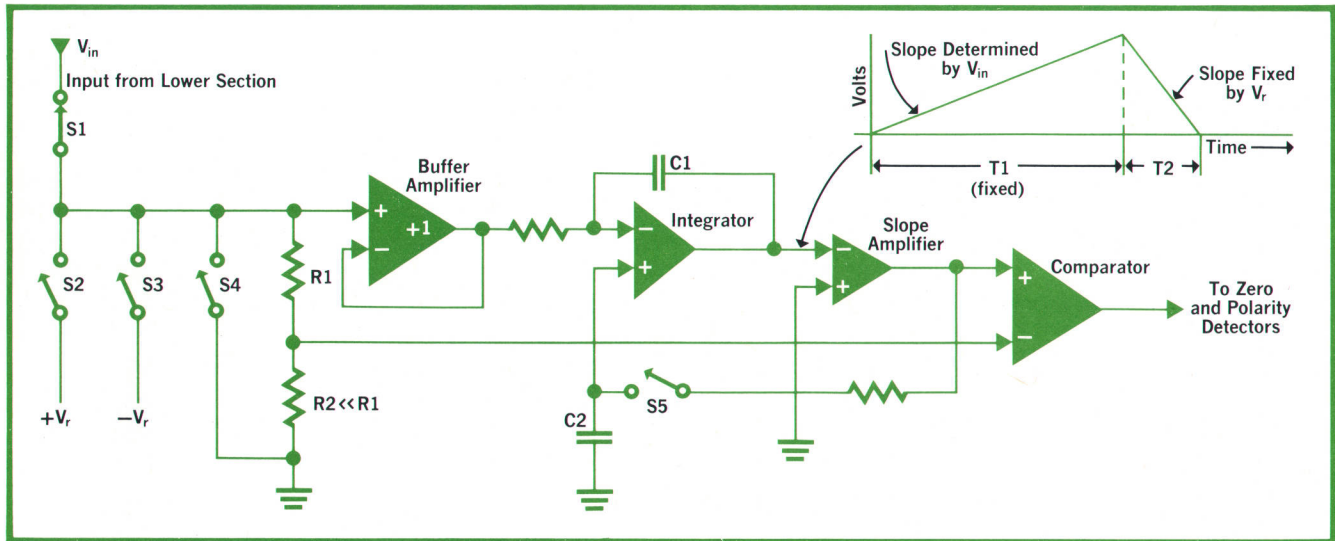

Fig. 4. Analog-to-digital converter in new Multimeter consists of voltage-to-time converter, shown here, and digital accumulator shown in Fig 5. Voltage-to-time converter generates time interval ( $T_2$ ) proportional to input voltage ( $V_{in}$ ).

to 10,000 clock pulses and  $V_r$  equal to  $\pm 1$  volt, the count accumulated during the discharge can be displayed as the measured voltage.

#### Inherent Advantages

The dual-slope technique is widely used because certain potential sources of error are self-canceling. For example, any long-term changes in the clock rate or in the integrator resistor and capacitor affect both the up and down charging rates and thus do not affect the count ratio.

Another advantage is that the input signal is integrated during the up ramp so that noise and other interference is averaged out. In the 3470 System, the time for the up ramp is made exactly 1/30 of a second\* thereby reducing the effect of power-line hum on the reading by at least 60 dB.

#### Non-Self-Canceling Errors

One critical area in this technique is the operation of the detectors and gate that control the clock count. In the new instrument, a 26-dB amplifier is inserted between the integrator and zero detector to increase the slope of the integrator output, and thus reduce the area of uncertainty around zero detection. The slope amplifier, however, introduces a nonlinear delay that shifts the time of zero crossover. An attenuated portion of the reference voltage is introduced into the out-of-phase input of the comparator during the down ramp (through R1, Fig. 4) to shift the zero-crossover point in a direction

that eliminates nonlinearity and the clock count is adjusted to compensate for the time delay.

Any offsets in the buffer amplifier or other parts of the circuit can cause nonlinearities as well as zero-detection errors. An 'auto-zero' technique, first used in HP's Model 405A Digital Voltmeter<sup>2</sup>, removes the effects of such offsets. Just before a measurement cycle begins, the input to the buffer amplifier is grounded through S4 and any offset at the output of the slope amplifier is applied to capac-

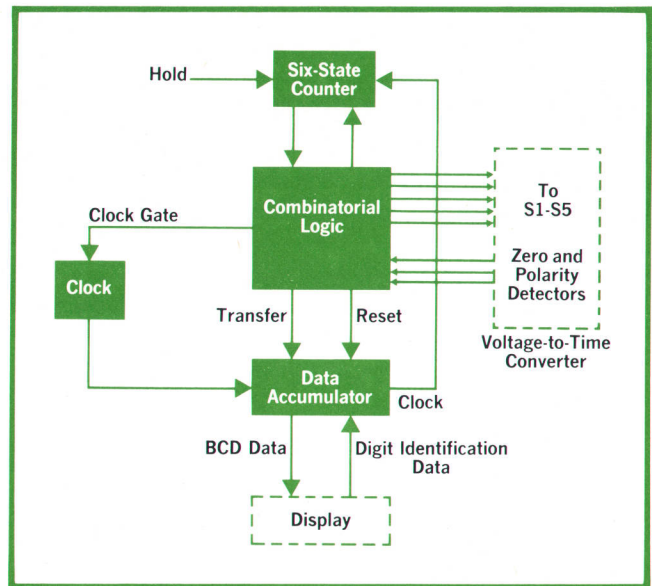
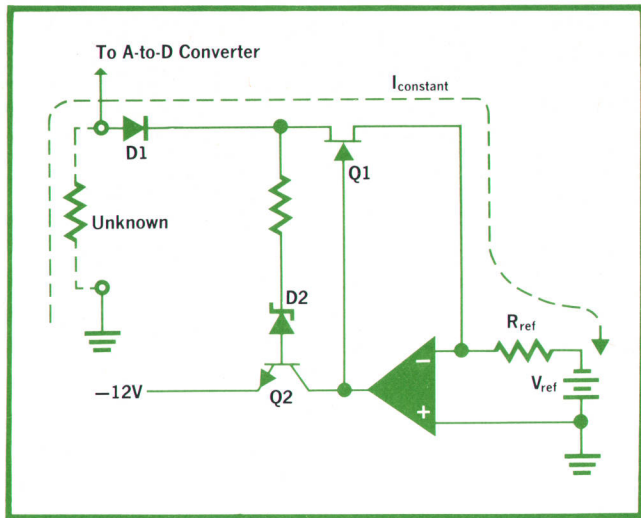

Fig. 5. Digital controller issues commands according to state of six-state counter. Hold input makes it possible to cycle counter one step at a time during service procedures.

\*For 60-Hz power-line operation. Voltmeters for 50-Hz operation have a charge time of 1/50 of a second.





**Fig. 6.** Ohms converter has amplifier that adjusts series regulator Q1 impedance to maintain current through  $R_{ref}$ , and thus through unknown, constant. Voltage across unknown therefore is proportional to unknown's resistance.

itor C2 through S5 (Fig. 4). During the measurement, the offset stored on Capacitor C2 is applied to the integrator input, canceling the offset.

### Controlling the Cycle

In actual practice, time must be allowed between the various operations just described to allow distributed capacitances to charge, amplifiers to settle, and switching transients to die out. In the new instrument, stabilizing periods are inserted between the operating periods to give a total of six periods. All switching and logic signals in the control section are derived as a function of the contents of a six-state counter that controls the operational sequence.

The various functional parts of the control logic section are shown in Fig. 5. Most of the action takes place in the data accumulator, an MOS chip developed by Hewlett-Packard's Santa Clara Division. This single device contains the totalizing decades, storage decades, and associated logic needed for reset and transfer functions. Also included is logic circuitry for providing the display with the measurement data in digit-serial, bit-parallel BCD format. All in all, this one component replaces about 12 standard TTL IC's, and it dissipates only 300 mW.

The combinatorial logic block provides drive signals for the FETs that serve as the switches in the dual-slope converter, and it generates control signals for the other blocks.

Information in the storage section of the data accumulator is transferred to a character generator that activates the appropriate control lines to the

light-emitting diode (LED) display. To allow flexibility in plug-on designs, the four BCD data lines and the three digit-identification lines, along with important timing signals and flags, are brought to the connector that joins with the lower section. Actually, the four BCD data lines are routed from the data accumulator, through the lower section and then to the display to allow the data to be modified on the way. If the display were to read in dB, for example, an appropriate constant could be added or subtracted to account for changes in range.

### Multimeter Section

The Multimeter section (Model 34702A) transforms dc voltages, ac voltages, and resistance into a dc voltage within the range of  $-1.9999$  to  $+1.9999$  volts for application to the display section (Fig. 3).

A single attenuator is used for both ac and dc, reducing the number of calibration adjustments needed. Minimum loading of the attenuator for ac was assured by using a unity-gain buffer amplifier ahead of the ac-to-dc converter. The converter itself is an average-responding type, using Schottky-barrier diodes in a half-wave rectifier that is included in a feedback loop around the drive amplifier.

### Protected Ohms Converter

One area that has caused problems for many users of digital multimeters has been the possibility of damage to the ohms converter by accidental application of an external voltage to the OHMS input terminals. The chances of this happening to the new Multimeter were reduced by providing a separate pair of terminals for resistance measurements. In addition, the ohms converter was modified to permit application of up to 350 volts of either polarity to the OHMS input.

As shown in Fig. 6, the ohms converter is protected against negative voltages by diode D1. A voltage greater than  $-2V$  reverse biases D1, isolating the constant-current generator from the input. Positive voltages greater than 4 volts at the input exceed the breakdown voltage of zener diode D2, turning on Q2 which in turn shuts off FET Q1, again isolating the constant-current generator. The allowable voltage is thus voltage-breakdown limited rather than power limited.

### Universal Use

To make the new 3470 Measurement System usable in most parts of the world, the line-voltage switch has two low-voltage positions (100V, 220V) in addition to the customary 120V and 240V positions. Also, the front-panel controls are labeled with



internationally agreed upon symbols.

Wherever the instrument may be, a wired-in jumper in the display section can be clipped to a test point to give a quick check of the display and control logic performance (should read '-10000' with lower section attached).

### Acknowledgments

Many thanks are due the following for their technical contributions and also for their contributions to this article: Greg Boxleiter, digital design; Jim Eller, ohmmeter circuits; Art Dumont, ac converter; Eugene Packer, power supplies and battery and BCD modules; and Gary Peterson, product design. Many thanks are also due Al Boswell and John Hettrick for their help in getting the instrument into production, and to Bill Kay for guidance and counsel.

### References

1. I. T. Band, H. J. Jekat, E. E. May, "Lilliputian Measuring System Does Much, Costs Little," Hewlett-Packard Journal, August 1969.
2. "Low-Speed 'Chopping' Improves Digital Voltmeter Accuracy," Electrical Design News, August 1959.



### Albert Gookin

Fresh out of the University of California at Berkeley with a BSEE degree, Al Gookin joined the HP Loveland (Colorado) Division in 1965, going right to work with the team developing the Model 3460A Digital Voltmeter. Al continued on with the Models 3461A and 3462A and he also worked on the 3450A Digital Multimeter and 3403A True-rms Voltmeter before assuming project leadership for the 3470 Measurement System. Along the way, he earned his MSEE at Colorado State University in the HP Honors Cooperative Program. Al's outside interest range from stamp and coin collecting to motorcycling and landscaping.

## SPECIFICATIONS

### HP Model 3470 Measurement System (34740A Display with 34702A Multimeter section)

**AC and DC VOLTAGE**  
**FULL RANGE DISPLAY:**  $\pm 1.0000$  V  $\pm 100.00$  V  
 $\pm 10.000$  V  $\pm 1000.0$  V  
**OVERRANGE:** 1000 V Range: 20%.  
 All other ranges: 100% (19999 max reading).  
**RANGE SELECTION:** Manual pushbuttons.  
**INPUT TERMINALS:** Floating pair.  
**INPUT IMPEDANCE:**  
 1 and 10 V ranges:  $\pm 11.1$  M $\Omega$   $\pm 0.1\%$ , 65 pF max.  
 100 and 1000 V ranges: 10.1 M $\Omega$   $\pm 0.1\%$ , 65 pF max.  
**MAXIMUM INPUT VOLTAGE:**  
 High to Low:  $\pm 1200$  V dc or rms except on 1 V ac range, where there is 2.5 x 10<sup>4</sup> V-Hz limit with minimum of 300 V rms.  
 Low to chassis:  $\pm 500$  V.  
**DC VOLTAGE ONLY**  
**ACCURACY** (30 days, +23°C  $\pm 5^\circ$ C,  $\leq 95\%$  RH):  $\pm (0.03\%$  of reading + 0.01% of range).  
**EFFECTIVE COMMON MODE REJECTION** (1 k $\Omega$  unbalance)  
 DC:  $> 80$  dB.  
 50 Hz (Option 050):  $> 120$  dB (50 Hz  $\pm 0.1\%$ ).  
 60 Hz (Option 060):  $> 120$  dB (60 Hz  $\pm 0.1\%$ ).  
**NORMAL MODE REJECTION**  
 50 Hz (Option 050):  $> 60$  dB (50 Hz  $\pm 0.1\%$ ).  
 60 Hz (Option 060):  $> 60$  dB (60 Hz  $\pm 0.1\%$ ).  
**READING RATE:** Option 050, 8/s, fixed;  
 Option 060, 5/s, fixed.  
**AC VOLTAGE ONLY**  
**FREQUENCY RANGE:** 45 Hz to 100 kHz.  
**INPUT COUPLING:** ac, max dc blocking of  $\pm 600$  V.  
**ACCURACY** (30 days, +23°C  $\pm 5^\circ$ C,  $\leq 95\%$  RH):  
 45 Hz to 20 kHz:  $\pm (0.25\%$  of reading + 0.05% of range).  
 20 kHz to 100 kHz:  $\pm (0.75\%$  of reading + 0.05% of range).  
**EFFECTIVE COMMON MODE REJECTION** (1 k $\Omega$  unbalance):  
 50 Hz (Option 050):  $> 60$  dB (50 Hz  $\pm 0.1\%$ ).  
 60 Hz (Option 060):  $> 60$  dB (60 Hz  $\pm 0.1\%$ ).  
**RESPONSE TIME:**  $< 2$  s within  $\pm 0.3\%$  of final value or 20 counts, whichever is greater.  
**OHMS**  
**FULL-RANGE DISPLAY:** 100.00  $\Omega$  100.00 k $\Omega$ ;  
 1.0000 k $\Omega$  1.0000 M $\Omega$ ;  
 10.000 k $\Omega$  10.000 M $\Omega$ .  
**OVERRANGE:**  $\pm 100\%$  on all ranges.  
**ACCURACY** (30 days, +23°C  $\pm 5^\circ$ C,  $\leq 95\%$  RH):  
 10 M $\Omega$  range:  $\pm (0.25\%$  of reading + 0.02% of range).  
 All other ranges:  $\pm (0.05\%$  of reading + 0.02% of range).  
**INPUT TERMINALS:** Floating pair (different from voltage input).  
**CURRENT THROUGH UNKNOWN:** 10 mA on 100  $\Omega$  range decreasing

by factor of 10 on each higher range.  
**OVERLOAD PROTECTION:**  $\pm 350$  V peak (248 V rms sine wave).  
**34740A DISPLAY with 34701A DC VOLTMETER**  
 Specifications same as dc voltage portion of 34702A Multimeter except:  
**INPUT RESISTANCE:** 10 M $\Omega$   $\pm 0.1\%$  on all ranges.  
**GENERAL**  
**POWER:** 100/120/220/240 V  $-10\%$ ,  $+5\%$  switchable; 48 Hz to 440 Hz, 8.7 VA.  
 Option 050: Measurement integration interval optimized for maximum rejection of 50 Hz interference on signal.  
 Option 060: Measurement integration interval optimized for 60 Hz operation.  
**DIMENSIONS:** Each module: 6 1/4 in W x 1 3/4 in H x 9 3/4 in D (157 x 44 x 247 mm).

**WEIGHT:**  
 34740A Display: 3 lb (1,35 kg)  
 34701A DC Voltmeter: 2 lb (0,90 kg)  
 34702A Multimeter: 2 lb (0,90 kg)  
 34720A Battery Section: 5 lb (2,25 kg)  
 34721A BCD Module: 1 1/2 lb (0,67 kg)  
**PRICES** (domestic USA only):  
 34740A Display, \$325  
 \*Option 050, 50 Hz operation, no charge  
 \*Option 060, 60 Hz operation, no charge  
 34701A DC Voltmeter, \$150  
 34702A Multimeter, \$275  
 34720A Battery Module, \$200  
 34721A BCD Module, \$175.  
**MANUFACTURING DIVISION:** LOVELAND DIVISION  
 815 Fourteenth Street, S.W.  
 Loveland, Colorado 80537  
 \* Must order either option 050 or 060.

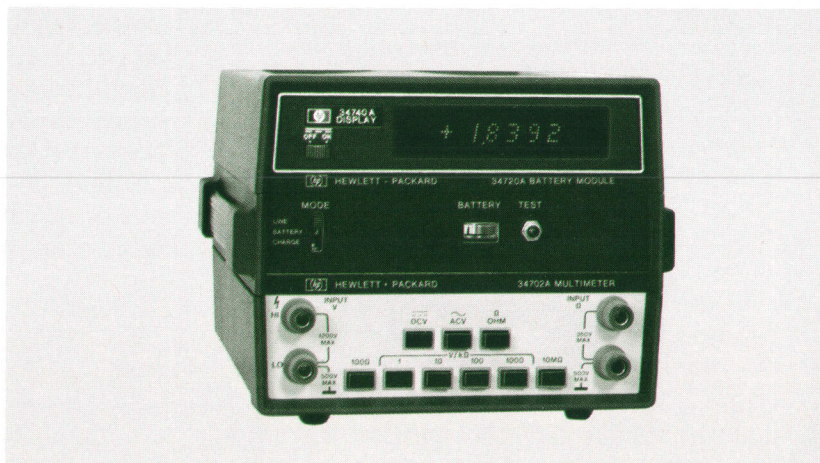



# A New Five-Digit Multimeter That Can Test Itself

*Along with 5-digit resolution, guarded inputs, and other attributes of a precision multimeter, this one has an enhanced confidence factor: it can interrogate itself to verify that all goes well.*

By Lee Thompson

**I**NSTRUMENTS WITH SOME 'THINKING' CAPABILITY—e.g., voltmeters that decide for themselves what range they should be on, counters with variable time bases that 'calculate' quantities like rpm from measurements of frequency—have been with us for some time. With the advent of low-cost solid-state memories and large-scale integrated circuits, however, really high-powered 'thinking' capability can now be built at low cost into all types of instruments.

Recently described in these pages were two frequency synthesizers that use digital processors with programs stored in read-only memories (ROMs). With just a few commands from the calculator-like keyboards, these instruments calculate and generate whole series of accurately-known frequencies.<sup>1,2</sup>

Then, of course, there is the HP Model 5360A Computing Counter, a pioneering 'intelligent' instrument introduced three years ago that not only uses stored programs to control measurements, but which also performs sophisticated calculations on the measurement data, giving highly accurate information in an instant.<sup>3</sup>

Now another capability of digital processor control emerges. Described in this article is a new Digital Multimeter (Model 3490A) that is capable of testing itself. A significant point about the self-test capability is that it was added to the instrument *without increasing the cost*—the initial design already included a digital processor for instrument control, so the self-test capability could be included merely by adding programs to those already stored in ROM.

Why self-test? Because it adds a major confidence factor. As any experienced engineer is painfully aware, there are times when measurements come

out all wrong, but the source of the problem is far from obvious. Is it really the unit under test, or is it a power supply some place?—or a signal source?—or could it be the voltmeter? Self-test eliminates the voltmeter as the offender and gives the engineer confidence in using it for testing the rest of the system.

Self-test also simplifies programs for automatic systems. Just two instructions can program the voltmeter to check itself and indicate its readiness to make a measurement. The self-test capability also saves considerable time in the repair and calibration lab.

## The 3490A

The instrument in which this self-test capability is found is a 5-digit, autoranging, fully-guarded, integrating Multimeter with a very modest price (Fig. 1). The most sensitive dc range is 100 mV full scale, giving the instrument 1  $\mu$ V resolution. Accuracy is better than 0.01% of reading and the voltmeter overranges to 20% above full scale on all ranges except the 1000-volt range. The input is fully protected against excessive voltages, withstanding 1000 volts on all ranges including the 100 millivolt range. The instrument can make five readings per second and when autoranging to another voltage range, it switches at a five-per-second rate.

The new Multimeter also measures resistance by the four-wire technique in 6 ranges from 100  $\Omega$  full scale to 10 M $\Omega$ , and it measures ac voltages in four full-scale ranges from 1 to 1000 volts. Frequency range is 20 Hz to 100 kHz on the 100 and 1000 V ranges and 20 Hz to 250 kHz on the 1 and 10 V ranges.

Useful options increase the instrument's range of





**Fig. 1.** Model 3490A Digital Multimeter measures dc volts, ac volts and resistance with 10 ppm resolution. Model shown here has Ratio and Sample-and-Hold functions installed. Easy-to-decipher range and function control brings into view only those ranges needed for function selected. Depressing appropriate tab selects range desired. Slide-out instruction card includes operator instructions for using Multimeter to test itself.

capabilities. One is sample-and-hold. This option makes it possible to make exact measurements at selected points on changing voltages, such as measuring peak amplitudes or determining amplifier settling times. Another option is ratio measurements, both dc/dc and ac/dc. Yet other options include remote control by either standard BCD inputs or by the new 'party-line' programming that allows the instrument to operate in parallel with other instruments on only 12 programming lines. Both remote control options have fully isolated digital inputs.

### Self-Testing

How can a voltmeter check itself? In the 3490A, the quickest test is one that causes the instrument to read its own internal positive reference voltage using the negative reference voltage as the measurement reference. The measurement automatically repeats with the roles of the reference voltages interchanged. This gives a quick indication that the voltmeter is indeed ready to make measurements. This test also discloses any voltage level difference between the reference sources.

Another test actually is a series of 10 tests that the voltmeter steps through automatically. When this test is initiated, the instrument autoranges one step for each reading, up through all ranges and then back down again. During each step, the data counters are permitted to count for periods of time that differ for each range. The operator can compare the resulting readings with a list on a pull-out instruction card attached to the underside of the instrument. If the series of readings agree with the card, the operator can be sure that the display, ranging and counting circuits, and at least 70% of the logic, are all functioning correctly.

Other tests, more useful for troubleshooting and calibration, check the calibrations of the input attenuator and amplifier and check for amplifier offsets in various parts of the instrument. The tests

can be used in combinations to isolate problems to one particular area of the instrument. The tests also make it possible to verify calibration of all dc-voltage ranges with only two voltage standards

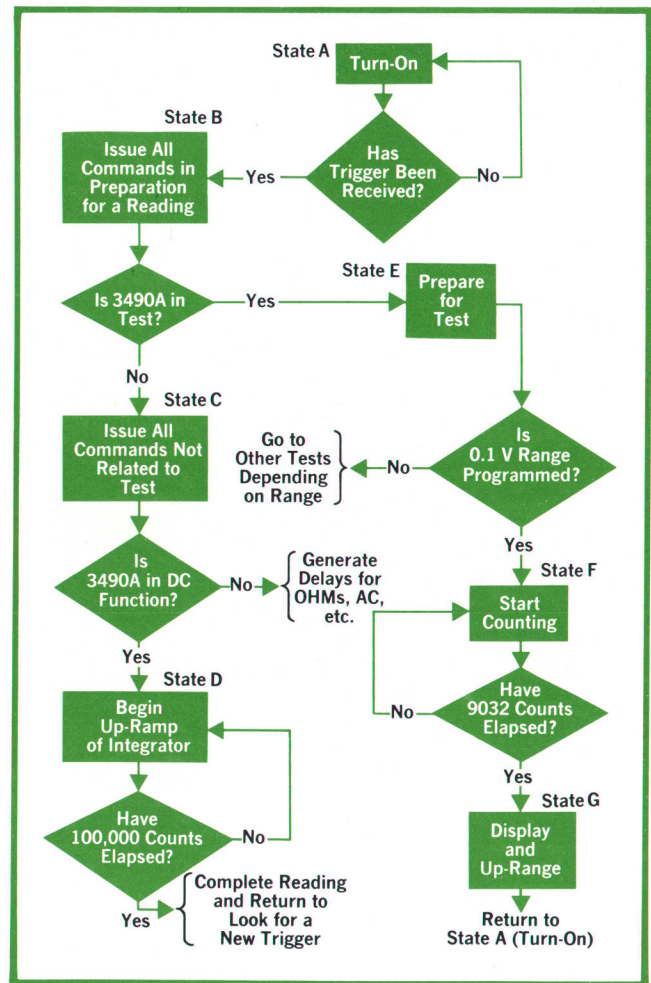

**Fig. 2.** Typical flow chart used in algorithmic state machine logic design illustrates how additional capabilities can be added to instrument that has digital processor. Self-test capability was included in new Multimeter by inserting test qualifier (second diamond from top) in normal instrument routine and then adding test programs.



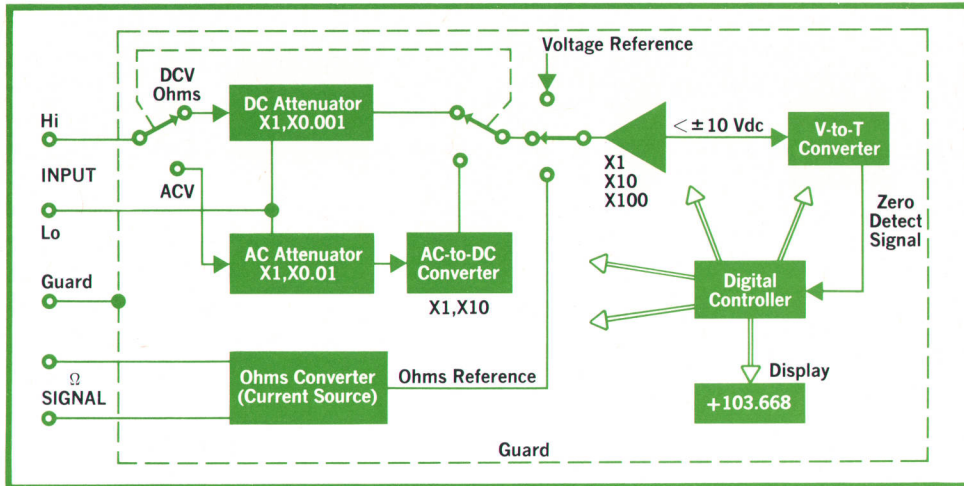

**Fig. 3.** Simplified block diagram of Model 3490A Multimeter in its basic configuration. Input signals go directly into guard (metal shield that electrically isolates circuits from power line to avoid ground loops and give 140-dB suppression of common-mode signals). Digital information to and from external equipment is coupled into and out of guard by light-coupled isolators (not shown).

(1 and 10 V), thereby reducing the number of verification standards needed to support the instrument.

### An Algorithmic State Machine

The digital controller that performs all these tests, as well as controlling normal operation of the Multimeter, is a read-only-memory-driven sequential machine. Procedures or algorithms that the controller executes for measuring and testing can be described by flow charts, one of which is shown in Fig. 2. The rectangular boxes contain machine operations executed during specific time intervals known as machine states with the sequence of operations determined by the diamond-shaped decision boxes. At the completion of each state time, the controller advances to the next state indicated.

The design of the controller is based on a set of procedures known as Algorithmic State Machine Logic design, developed at the HP Laboratories in Palo Alto. One of the advantages of this technique is that a flow chart can be converted to a reliable hardware design that in turn can be translated directly into a ROM design. This approach leads to microprogrammed machines with completely specified behavior. Special features, such as self-test, are easily worked into the program without requiring additional hardware.

### How it measures

A block diagram of the new Model 3490A Multimeter in its basic configuration is shown in Fig. 3. It uses the dual-slope technique to convert a dc voltage into digital information with circuits that operate in much the same way as the 3470 Measurement System, described in the article beginning on page 2.

As does the Model 3470, the 3490A Multimeter uses autozero circuits, a slope amplifier, and feed-forward offset to compensate for slope amplifier

delay ( Fig. 4, page 4 ). Additional refinements are needed, however, to insure the stability and noise immunity needed for 5-digit resolution. The integrator in the voltage-to-time converter, for instance, operates over a  $\pm 18$ -volt span which, with the  $\times 20$  slope amplifier, gives a slope of 3.6 mV per clock pulse, making it possible for the comparator to sense zero crossover closely enough to give a readout resolution of 10 ppm. Actually, the integrator can go to approximately 22 volts, about the limit possible with commonly-used IC op amps, allowing 20% overranging.

Any noise or switching transients on the signal could also affect the instant of zero-crossover detection. Transients appearing at the integrator summing junction would be coupled to the slope amplifier by the integrating capacitor itself. This noise is eliminated by tapping off the signal at the integrator summing junction and feeding it through a resistor network to the opposite-polarity input of the slope amplifier. Since both inputs to the slope amplifier then move in the same direction in response to a transient, the transient will not appear at the amplifier's output.

### Laser-Trimmed Gain

An input amplifier scales the input voltage to a range of  $\pm 10$  volts for the integrator input. This is a FET input, high-gain, low-noise, hybrid integrated circuit amplifier that gives the instrument an input impedance of greater than  $10^{10}$  ohms on the 0.1, 1, and 10 V ranges (the passive attenuator used on the 100 and 1000 V ranges gives an input impedance of 10 M $\Omega$ ).

The amplifier has a switched resistive feedback network to give selectable gains of  $\times 1$ ,  $\times 10$ , and  $\times 100$ . Switching is performed by FETs, mounted directly on the substrate. The resistors are thin



films deposited on the substrate and trimmed with a computer-controlled laser beam to a high degree of accuracy. The substrate is sealed with a metal cover to maintain the high input impedance over a wide range of humidities. Because of the close proximity of all the circuits on the substrate, thermal differences and the resulting thermal emf's are reduced significantly.

### AC Converter

The ac converter is an average-responding type calibrated to display the rms value of a sine-wave input. It uses the traditional half-wave rectifier enclosed in a feedback loop.

A block diagram is shown in Fig. 4. Ranging is provided by a passive input attenuator, switched in on the 100- and 1000-volt ranges, and a switched feedback network in the buffer amplifier that changes amplifier gain by a factor of 10. By using only one amplifier for both buffering and attenuation, the interaction of two separate amplifiers with attenuation is avoided, permitting an accuracy specification that is constant over the frequency range from 50 Hz to 100 kHz. The buffer amplifier (A1) is a wideband monolithic op amp that minimizes parasitic capacitance, extending the bandwidth on the 1- and 10-volt ranges to 250 kHz.

The output filter is a four-pole active filter optimized to allow the low end of the frequency range to be reduced to 20 Hz (50 Hz has commonly been the lower limit) while maintaining a one-per-second reading rate.

### Ohms Converter

The ohms converter supplies a constant current

to an unknown resistance through the front-panel  $\Omega$  SIGNAL terminals. The resulting IR drop across the unknown is then determined through connections made to the front-panel INPUT terminals. Separation of the voltage-carrying leads from the current-carrying leads removes the possibility of degrading the measurement with the IR drops developed across the current-carrying leads ( $R_{L1}$  and  $R_{L2}$  in Fig. 5). It is thus practical to include a 100  $\Omega$  range with its 1-milliohm resolution.

Resistance measurements are actually performed as ratio measurements, with the instrument determining the ratio of the unknown resistance to a known resistance inside the instrument. As shown in the diagram of Fig. 5, the same current ( $I_x$ ) flows through the unknown ( $R_x$ ) and the reference ( $R_{ref}$ ). The ratio of the IR drops across these resistances is thus the same as the ratio of the resistances. As a result,  $I_x$  does not have to be known precisely.

The instrument's voltage-to-time converter responds to the voltage across the unknown during the up-ramp (T1 in the timing diagram in Fig. 4, page 4) and to the voltage across the reference during the down ramp (T2). With T1 set at 100,000 clock counts, and  $R_{ref}$  scaled to be equivalent to the full-scale value, the count obtained during T2 can be displayed as the unknown resistance, with appropriate placement of the decimal point.

The  $\Omega$  SIGNAL terminals are fully protected against accidental application of voltages up to 250 volts rms continuously, and fuse-protected up to 1000 volts (see Fig. 5).

### Sample and Hold

The sample-and-hold option\* makes it possible to

\*Available fall 1972

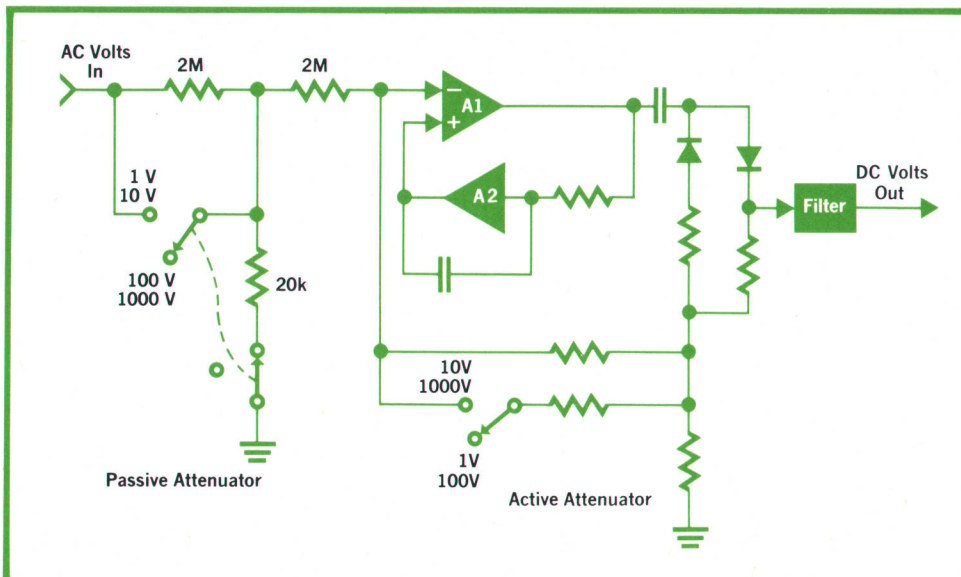

**Fig. 4.** Ac-to-dc converter combines attenuation and buffering function to gain 0.1% accuracy over wider frequency range (50 Hz to 100 kHz). Amplifier A2 stabilizes dc level of A1 so no zero adjustment is needed. As has been common practice, two diodes are in circuit to make feedback effective over complete cycle of ac waveform, although only one diode is needed for signal rectification.



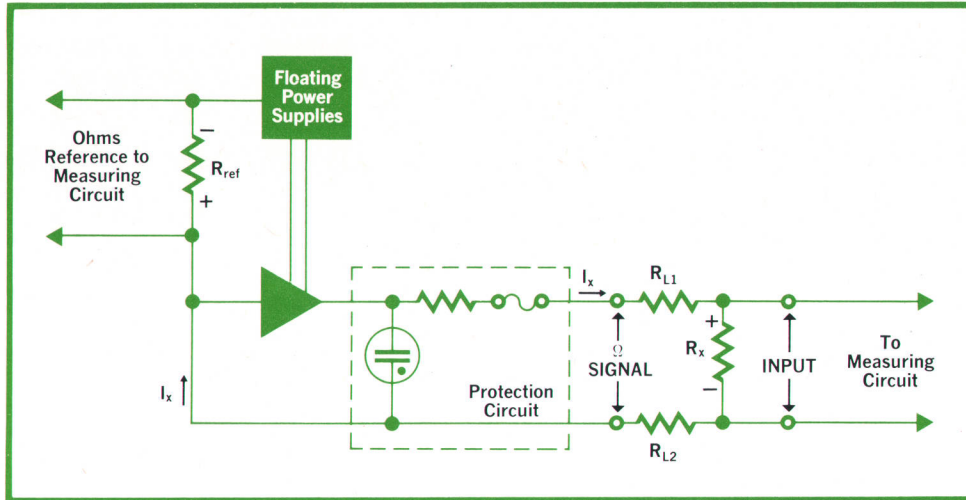

**Fig. 5.** Ohms converter supplies constant current through SIGNAL terminals to unknown resistance  $R_x$ . Instrument measures voltage drop across  $R_x$  through INPUT terminals, excluding voltage drops in current-carrying leads  $R_{L1}$  and  $R_{L2}$ . Instrument compares voltage drop across  $R_x$  to voltage drop across standard resistor  $R_{ref}$ . Gas-filled tube limits voltage applied to circuits by firing whenever excessive voltage is applied accidentally to Ohms terminals during resistance measurements. Voltage higher than 250 volts blows fuse.

measure a changing voltage at a particular instant in time, rather than integrating the voltage over the measurement interval.

Design criteria were fast acquisition of the signal but no appreciable sag during the measurement interval. Hence, sample and hold is performed in two steps, as shown in Fig. 6. The first sample-and-hold amplifier stores the input on a capacitor (C1) that is small enough to respond quickly to changes in the input voltage. The second amplifier has a larger capacitor (C2) that retains a sampled voltage without appreciable sag during the measurement interval.

When operating in the "Track-and-Hold" mode, the system is connected continuously to the input by way of switches S1, S2, and S3. At the instant a trigger is received, the Logic Controller opens S2, retaining the instantaneous signal voltage on capacitor C1. S3 remains closed for an additional 2 ms, allowing the charge on C2 to reach the same level as C1. S3 then opens and C2 holds the charge while

a measurement of its voltage is made. This mode is useful for continuously tracking and measuring signals with small perturbations (less than 10% of full-scale).

For large changes, such as measuring the top of a full-scale voltage step, the instrument is operated in the "Acquire-and-Hold" mode. This mode inserts a delay between the trigger and the opening of S2 (e.g., 256  $\mu$ s on the 1 V range), allowing the input amplifier to stabilize to within rated accuracy at the new voltage level before S2 is opened.

The voltage retained on a third holding capacitor (C3) drives an output for monitoring the waveform as sampled. A third holding capacitor is required because in practice, the reference voltage is switched through the sample-and-hold amplifier on the down-ramp phase of the measurement. S4 remains open during this time so the reference voltage will not appear on the output.

An oscilloscope can be helpful when measure-

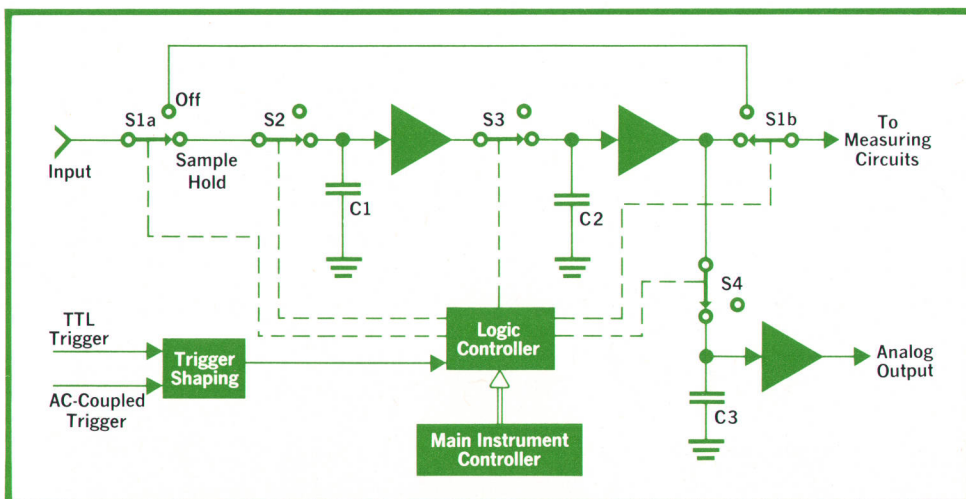

**Fig. 6.** Sample-and-hold retains instantaneous value of input level on capacitor C1 when switch S2 opens. Switch S3 opens 2 ms later, giving time for C2 to charge to same voltage as C1. Instrument measures voltage retained on C2.



ments are made at points along a repetitive waveform. The delayed-sweep trigger of the oscilloscope can be used as a sample-and-hold trigger. The delayed-sweep intensity dot can then be moved along the waveform to select the sampling points.

### Acknowledgments

The original self-test algorithm was conceived by David Palermo, who designed the logic controller. John McDermid was responsible for the input amplifier, including development of the hybrid switching network, and the analog-to-digital converter. Larry Bower had responsibility for the ohms converter and the power supplies, as well as providing timely suggestions in other design areas. David Crook was responsible for both the analog and digital designs in the sample-and-hold. Arnold Joslin was involved in the initial phases of the product design, which was completed by Michael Williams. Robert Livingood is currently designing the "party-line" remote control option.

Special thanks are due Bill Rothmeyer and Skip Beatty for their help in building and testing prototypes. John Hettrick was particularly helpful during the transition to production. Also, special thanks are due William Kay for his guidance and timely inputs during the entire development program.

### References

1. J. C. Shanahan, "Uniting Signal Generation and Signal Synthesis," Hewlett-Packard Journal, Dec. 1971.
2. C. A. Kingsford-Smith, "The Incremental Sweep Generator—Point-by-Point Accuracy with Swept-Frequency

Convenience," Hewlett-Packard Journal, July 1972.

3. G. B. Gordon and G. A. Reeser, "Introducing the Computing Counter," Hewlett-Packard Journal, May 1969.

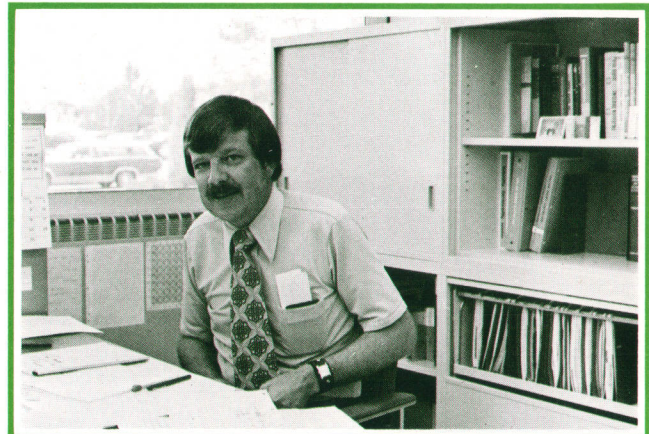

### Lee Thompson

Lee Thompson started with HP as product designer in 1966, contributing the product design and some circuit designs to the true-rms converter in the Model 3450A Digital Multimeter. He also designed the amplifier for the true-rms converter in the Model 3480A Digital Multimeter before becoming project leader for the 3490A Digital Multimeter.

Lee earned his BSEE degree at the University of Texas at Austin (1966) and an MSEE degree at Colorado State University in the HP Honors Cooperative Program. He's a member of Tau Beta Pi. Outside of working hours, he plays golf and enjoys the usual Colorado attractions (hiking, mountain climbing, etc.) but he also devotes much time to youth activities, being instrumental in setting up a local drug-abuse center.

### SPECIFICATIONS

#### HP Model 3490A Digital Multimeter

**DC VOLTAGE**  
**FULL RANGE DISPLAY:**  $\pm 1.00000 \text{ V}$   $\pm 10.0000 \text{ V}$   
 $\pm 1.00000 \text{ V}$   $\pm 100.000 \text{ V}$   
 $\pm 1000.00 \text{ V}$   
**OVERRANGE:** 20% on all ranges except 1000 V range.  
**RANGE SELECTION:** manual, automatic, or remote (optional).  
**ACCURACY (90 days,  $23^\circ\text{C} \pm 5^\circ\text{C}$ ):**  
 0.1 V range:  $\pm(0.01\%$  of reading  $+ 0.005\%$  of range).  
 1 V to 1000 V range:  $\pm(0.01\%$  of reading  $+ 0.002\%$  of range).  
 Notes: On 1000 V range, add 0.04 ppm/volt to % of reading specification. Thermal EMFs generated externally may be compensated by using rear-panel zero adjust.  
**TEMPERATURE COEFFICIENT ( $0^\circ\text{C}$  to  $50^\circ\text{C}$ ):**  
 0.1 V range:  $\pm(0.001\%$  of reading  $+ 0.0007\%$  of range)/ $^\circ\text{C}$ .  
 1 V to 1000 V range:  $\pm(0.001\%$  of reading  $+ 0.0003\%$  of range)/ $^\circ\text{C}$ .  
**INPUT:** Fully guarded with 140 dB ECMR at dc and 60 Hz  $\pm 0.1\%$  with 1 k $\Omega$  imbalance between Guard and Low.  
**MAXIMUM INPUT VOLTAGE:** High to Low,  $\pm 1500 \text{ V}$  peak on all ranges; Guard to Chassis,  $\pm 500 \text{ V}$  peak; Guard to Low,  $\pm 200 \text{ V}$  peak.  
**INPUT RESISTANCE:** 0.1 V to 10 V ranges:  $> 2 \times 10^{10} \Omega$ .  
 100 V and 1000 V ranges:  $10 \text{ M}\Omega \pm 0.15\%$ .  
**MAXIMUM READING RATE:** 5 readings/s.  
**NORMAL MODE REJECTION RATIO:**  
 Option 050:  $> 50 \text{ dB}$  at 50 Hz  $\pm 0.1\%$ .  
 Option 060:  $> 50 \text{ dB}$  at 60 Hz  $\pm 0.1\%$ .

**AC VOLTAGE**  
**FULL RANGE DISPLAY:** 1.00000 V 100.000 V  
 10.0000 V 1000.00 V  
**OVERRANGE:** 20% on all ranges except 1000 V range.  
**RANGE SELECTION:** manual, automatic, or remote (optional).  
**ACCURACY (90 days,  $23^\circ\text{C} \pm 5^\circ\text{C}$ ):**  
 20 Hz–50 Hz:  $\pm(0.25\%$  of reading  $+ 0.05\%$  of range).  
 50 Hz–100 kHz:  $\pm(0.1\%$  of reading  $+ 0.025\%$  of range).  
 100 kHz–250 kHz (1 V and 10 V ranges only):  
 $\pm(0.75\%$  of reading  $+ 0.06\%$  of range).  
 Notes: Guard must be connected to Low. On 1000 V range, add

0.01 ppm/(volt-kHz). Specifications are for input levels above 1/100th of full scale.  
**TEMPERATURE COEFFICIENT ( $0^\circ\text{C}$  to  $50^\circ\text{C}$ ):**  $\pm(0.002\%$  of reading  $+ 0.001\%$  of range)/ $^\circ\text{C}$ .  
**INPUT IMPEDANCE:** 2 M $\Omega$   $\pm 1\%$  shunted by  $< 65 \text{ pF}$  ( $< 90 \text{ pF}$  with rear terminals).  
**MAXIMUM READING RATE:** 1 reading/s.  
**RESPONSE TIME:**  $< 1\text{s}$  to within rated accuracy for step input applied coincident with encode trigger.  
**MAXIMUM INPUT VOLTAGE:** 1000 V rms;  $\pm 1500 \text{ V}$  peak.

**OHMS**  
**FULL RANGE DISPLAY:** 100000 k $\Omega$  100.000 k $\Omega$   
 100000 k $\Omega$  10000.0 k $\Omega$   
 10.0000 k $\Omega$  10000.0 k $\Omega$   
**OVERRANGE:** 20% on all ranges.  
**RANGE SELECTION:** manual, automatic, or remote (optional).  
**ACCURACY (90 days,  $23^\circ\text{C} \pm 5^\circ\text{C}$ ):**  
 0.1 k $\Omega$  range:  $\pm(0.012\%$  of reading  $+ 0.005\%$  of range).  
 1–100 k $\Omega$  ranges:  $\pm(0.012\%$  of reading  $+ 0.002\%$  of range).  
 1000 k $\Omega$  range:  $\pm(0.015\%$  of reading  $+ 0.002\%$  of range).  
 10,000 k $\Omega$  range:  $\pm(0.035\%$  of reading  $+ 0.002\%$  of range).  
**TEMPERATURE COEFFICIENT ( $0^\circ\text{C}$  to  $50^\circ\text{C}$ ):**  
 0.1 k $\Omega$  range:  $\pm(0.001\%$  of reading  $+ 0.0007\%$  of range)/ $^\circ\text{C}$ .  
 1 to 10,000 k $\Omega$  ranges:  $\pm(0.001\%$  of reading  $+ 0.0003\%$  of range)/ $^\circ\text{C}$ .  
**MAXIMUM VOLTAGE GENERATED ACROSS UNKNOWN:**  
 20 V for overload;  
 13 V for valid reading.  
**CURRENT THROUGH UNKNOWN:** 0.1 to 10 k $\Omega$  ranges:  $\approx 1 \text{ mA}$ .  
 100 to 1000 k $\Omega$  ranges:  $\approx 10 \mu\text{A}$ ;  
 10,000 k $\Omega$  range:  $\approx 1 \mu\text{A}$ .

**OVERLOAD PROTECTION:** Non-destructive to 250 V rms; Fuse-destructive to  $\pm 1000 \text{ V}$  peak.  
**MAXIMUM READING RATE:** 0.1 to 100 k $\Omega$  ranges: 5 readings/s.  
 1000 k $\Omega$  range: 4 readings/s.  
 10,000 k $\Omega$  range: 2 readings/s.

### GENERAL

**WARM-UP TIME:** one hour warm-up required to meet all specifications on 0.1 V and 0.1 k $\Omega$  ranges. Thirty minutes warm-up required to meet all other specifications.  
**HUMIDITY RANGE:**  $< 95\%$  R.H.,  $0^\circ\text{C}$  to  $40^\circ\text{C}$ .  
**DIMENSIONS:** 163 $\frac{1}{2}$  in W x 3 $\frac{3}{8}$  in H x 18 $\frac{1}{2}$  D (425 x 98 x 468 mm).  
**WEIGHT:** 20 $\frac{1}{2}$  lbs (9.32 kg). When rack-mounted, requires support at rear.  
**POWER:** 100/120/220/240 V  $\pm 5\%$ ,  $-10\%$ , 48 Hz to 400 Hz line operation,  $< 60 \text{ VA}$  with all options.  
**OPTIONS:**  
 OPTION 050: Measurement integration interval optimized for maximum rejection of 50 Hz interference on signal.  
 OPTION 060: Measurement integration interval optimized for 60 Hz operation.  
 OPTION 020: Systems expand; includes rear terminals in parallel.  
 OPTION 021: BCD full-parallel data output; 1-2-4-8 code, either high-true or low-true logic selected by internal switch. Needs option 020.  
 OPTION 022: Remote control; 1-2-4-8 low-true logic. Needs option 020.  
 OPTION 030 (in development): ASCII-coded remote control and output data.  
 OPTION 040: Sample-and-hold (available fall 1972).  
 OPTION 080: Three-wire ratio (available fall 1972).  
**PRICES (domestic USA only):**  
 3490A (includes dc volts, ac volts, and ohms): \$1650.  
 Option 020: \$200. \*Option 050: no charge.  
 Option 021: \$250. \*Option 050: no charge.  
 Option 022: \$175. Option 080: (to be less than \$250).  
 Option 040: (to be less than \$650).

**MANUFACTURING DIVISION:** LOVELAND DIVISION  
 815 Fourteenth Street, S.W.  
 Loveland, Colorado 80537

\* Must order either option 050 or 060.



# Functional Modularity Helps Designer and User of New Measurement and Control Subsystem

*A method of allocating functions to modules in a system, functional modularity gives a new industrial system-in-a-box a high degree of versatility at reasonable cost.*

By James M. Kasson

**V**ERSATILITY IS IMPORTANT to both the manufacturer and the user of automatic measurement and control systems. The manufacturer must produce systems to satisfy applications ranging from automobile exhaust emission analysis to nuclear power plant monitoring. Even within a particular application, the user's needs frequently change, and his system should be capable of meeting these new needs.

The best way to provide the necessary versatility is to make the system modular. However, modularity calls for tradeoffs. If small enough modules are used, it may be possible to select the right ones and assemble anything from an integrated circuit tester to a TV set. Of course, the integration cost will be high, because each system is individually engineered. On the other hand, as more and more circuitry is put into a module, its use becomes more specialized, production volume drops, and module costs start to climb.

Many test and measurement systems in the past have been constructed using individual instruments as modules. For many industrial applications, such a system represents overkill. The accuracy of the programmable instruments is greater than necessary, the operator inter-

face for each instrument is not needed, space requirements are larger than necessary, and the cost of constructing individual instruments is high. Most instruments are constructed so they must be separately interfaced to the computer, and means must be devised for routing analog signals from one place to another.

The HP 2440A Analog-Digital Interface, Fig. 1,

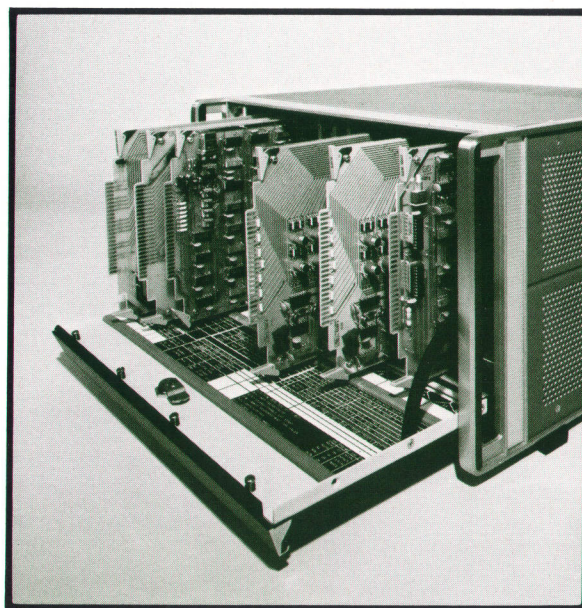

**Fig. 1.** Model 2440A Analog-Digital Interface is designed to serve as the interface between a computer and the sensors monitoring a physical process. It's configured for a variety of data acquisition and control applications by plugging appropriate modules into a combining case.

was designed for applications where moderate performance is acceptable, and cost and versatility are of great importance. This new system-in-a-box takes a new approach to the problems of computerized measurements, an approach which in many cases provides both reduced cost and increased versatility over systems composed of programmable instruments.

The 2440A is a combining case for modules composed of printed circuit cards. It has a power supply, a backplane to allow the modules to have analog and digital communication with each other and with the computer, and a set of rules that the designer of each module

must follow to assure that his module is compatible with others. The tasks normally performed by individual programmable instruments are separated into those directly related to the measurement



function (e.g., input scanner, amplifier, digitizer), and those used to support the measurement function (e.g., operator interface, power supply, mechanical support, digital interface). In the 2440A the direct measurement functions are accomplished on the printed circuit cards while, as far as possible, the support functions are relegated to the combining case, which is designed to serve in a wide variety of applications. The system is configured to a particular task by plugging a specific set of functional modules into the case.

### System Partitioning

The measurement system made up of these modules performs some task, which is made up of several functions. As an example, consider a system whose task is to control an assembly line. This task may be divided into the functions of monitoring the line by measuring several voltages, computing corrections, and controlling the line by generating control signals. The functions of measuring voltages may be further dissected into scanning, signal conditioning, and digitizing.

The partitioning of a system is the assignment of functions to modules. In the assembly-line example, the three main measurement functions may be accomplished in three separate modules, or the voltage-measuring and voltage-generating functions could be combined into one module. The decision as to how much circuitry a module should contain is made by trading off the lower manufacturing cost of large modules with the lower development costs and increased versatility of smaller modules.

The philosophy followed in the 2440A is to partition the system into the smallest possible modules that perform some function that is needed in a large number of systems. If this results in modules so small as to have an unreasonable amount of overhead, multiple identical functions are implemented in one module. This is *functional modularity*.

The result of this kind of partitioning is a collection of generally useful modules that may be connected together to perform a specific task. Commonly used functions are implemented in separate modules, so each module is useful in many different systems. The concept of functional modularity minimizes development time and money by maximizing the usefulness of each module and thus minimizing the number of modules that need to be designed for a new system. The availability of many functional modules may result in novel solutions to measurement needs. For example, an accurate oscillator may be implemented with a voltage-con-

trolled function generator, a counter, and a digital-to-analog converter, using the computer to close the feedback loop.

### Analog Communication

When a system is partitioned using the philosophy of functional modularity, there are many half-processed analog signals that must be passed among the modules. The 2440A allows for the necessary analog communication by providing a system of 36 analog buses, or lines that are common to all modules. Two of these are guarded—that is, surrounded by driven shields. A module's access to these guarded buses is obtained through an electronic switch and can be controlled by the computer.

The guarded buses are used in a manner analogous to the way a digital bus is used in a three-state TTL system. In a typical system, there are many modules that might control the voltage on the guarded buses, but at any instant, only one module is allowed to control the voltage on either bus; the others must present a high impedance to the buses.

The guards are driven by a unity gain amplifier connected to the bus at all times. The purpose of guarding is to reduce settling time of the dynamically switched signals and to reduce noise pickup.

In addition to the guarded buses, there are 34 unguarded analog buses. As a rule, signals are not switched on and off these buses dynamically. Instead, the use of these buses is determined by switches or jumpers on the modules which are set when a system is configured.

### Digital Communication and Control

The modules communicate with each other and with the control module using a 16-bit digital bus. Access to this bus is obtained through three-state gates. At any time, only one module is allowed to

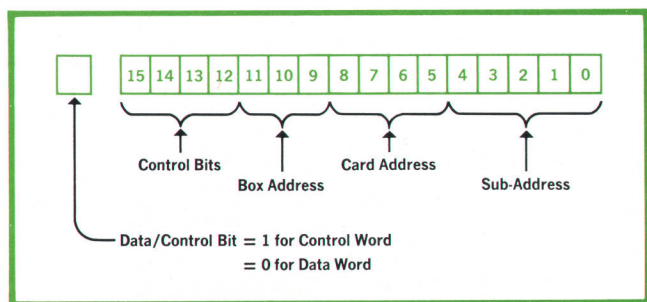

Fig. 2. Control of modules in 2440A Analog-Digital Interface is by means of control words transmitted on a 16-bit digital bus. Bus carries both control information and data among modules and computer.



## Modular Systems for Sensor-Based Data Acquisition and Control

An increasing number of computer applications, both in industry and research, involve the processing of data that is acquired in real time from transducers. Computerized systems for these applications take the general form shown in the block diagram: some real-time process is monitored and controlled by a minicomputer. In these systems the interface between the controller and the process sensors consists of two subsystems: an analog measurement subsystem and a digital input/output subsystem.

Hewlett-Packard's new 9600-Series systems are standard systems configured specifically for this type of sensor-based data acquisition and control application. Each 9600-Series system consists of an HP 2100A Computer, a teleprinter, a photoreader, a cabinet, peripherals appropriate to the software operating system (e.g., a disc drive), and of course, an analog subsystem and a digital subsystem.

The analog and digital subsystems in 9600-Series systems are most often the HP 2440A Analog-Digital Interface and the HP 6940A Multiprogrammer, respectively. These are new, highly modular devices designed to adapt to a wide variety of applications with minimal special engineering. They are described in the articles beginning on pages 13 and 20.

There are four basic systems in the 9600 Series. They differ chiefly in their software operating systems.

The operating system used in the 9600A, the least sophisticated and least expensive of the 9600 Series, is the Basic Control System (BCS). BCS allows the user to mix program languages for system flexibility. It has relocatable software for ease of programming. It provides for output buffering of data to help maintain system speed, and it manages the entire interrupt system. This system is well suited to the dedicated data-acquisition system application.

Adding a time-base generator and some additional software, the Data Acquisition and Control Executive (DACE), results in the 9600G system. The DACE software allows the user to schedule different data-acquisition tasks at different times and to change task parameters on-line. The 9600G is in essence a low-cost core-based real-time scheduler of data-acquisition and control programs.

Most sophisticated of the 9600 Series Data Acquisition and Control Systems are the 9600E and F Systems, which are based on the Real-Time Executive (RTE) operating system. These two systems are true multiprogramming, foreground-background operating systems with priority scheduling, interrupt handling, and program load-and-go capabilities. Both systems use a disc for mass storage.

The 9600E system uses the new HP 7900A Moving-Head Disc Drive (Hewlett-Packard Journal, May 1972). The 9600F uses a fixed-head disc. The two differ in disc access time,

the fixed-head disc being faster, and in data storage capacity. The 9600E has far greater storage capacity: 2.5 million words per disc drive and as many as four drives operated from a single controller. With a 9600E or 9600F system, several user-prepared programs can be run in real time concurrently with general-purpose background programs.

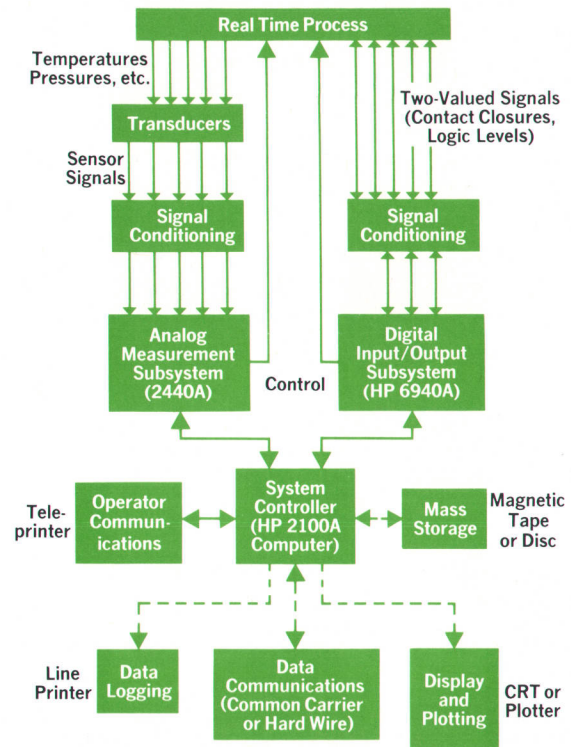

HP 9600 Series Data Acquisition and Control Systems

Besides the standard hardware and subsystems discussed in this issue, there are several other optional front ends, such as DVMS and crossbar and reed scanners. There are also peripherals such as magnetic tape, CRT displays, and data communications systems. Thus 9600-Series systems can be configured to solve a variety of sensor-based data acquisition and control problems. Systems can be stand-alone or distributed, and can automate a single process or an entire factory.

control the state of the digital bus. All other modules must be in the 'off' or high-impedance state. The digital bus is used to transmit both control information and data among modules. The presence of a control word is indicated by the data/control line, another three-state line associated with the digital bus. A logic one on the data/control line indicates a control word, and a logic zero indicates

a data word.

The format of the control word is given in Fig. 2. The control word contains two types of information: a module address and a function command. Addressing is usually performed according to physical position. The address field is divided into three subfields: a box address, a module or card address, and a subaddress. The box address is used



to select one of the eight possible 2440A mainframes in a system, the module address picks a module within that box, and the subaddress identifies a function on that module.

Within each mainframe, there are separate enable lines running from the control module to each module. The backplane addresses are decoded by the control module, and the appropriate enable line is activated. In a multi-box system, a digital expander module inserted in a control module slot performs the enabling of modules.

There are 12 modules per box, so there are four unused module addresses in the 4-bit address space. Since the box address is independent of the card address, in the combined box and module address space there are 32 unused combinations. These combinations may be used to address modules by function rather than by physical position. If this method is employed, the card must decode its address from the backplane; none of the enable lines will be activated. Addressing by function is especially useful when many cards must be enabled simultaneously.

If it is desired to pass more than the four-bit function command and the five-bit subaddress to a module, a control word is issued to get the attention of the module, and any number of data words (in which the state of the data/control line is zero) may then be issued. The format of the data word is completely free, since no module can be enabled by a data word.

All transfers of information on the backplane are asynchronous and take place in response to commands issued by the control card. There are

two principal reasons for using an asynchronous scheme. First, modules may function at any clock rate, thus freeing the module's internal circuitry from restrictions introduced by the mainframe. Second, it's desirable to have a quiet backplane for analog measurements, and an asynchronous scheme requires no clock signal. Where noise is very important, it's possible to halt all transfers of data by activating one of the control lines on the backplane.

### System Configuration

Once a library of functional modules is built up, the design of a system to perform a new task is greatly simplified. When faced with a new requirement, a designer may follow one of three courses, depending on the differences between the new system and previously designed systems. 1) It may be possible to configure the system by plugging the appropriate cards into a mainframe. The ability to change system configuration is not restricted to the designer; a user may take advantage of this feature to modify his system as his requirements change. 2) If all necessary functions are available but a new control feature is needed, the control card may be redesigned or reprogrammed. 3) If some new functions are necessary, the appropriate modules must be designed. These can be used together with some of the modules in the library. The newly designed modules may be added to the library, where they should be useful in future systems.

There are limitations to the types of systems that may be implemented using the 2440A. The analog

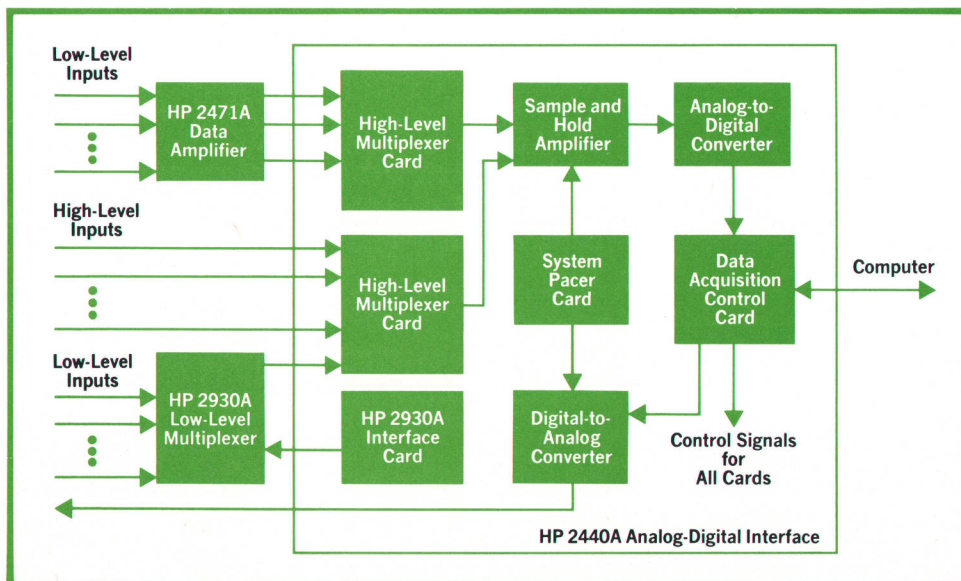

**Fig. 3.** 9600 Option G00 is the principal analog subsystem for 9600-Series Data Acquisition and Control Systems. It's one possible configuration of the 2440A Analog-Digital Interface.



bus is limited in its ability to accommodate high-frequency or low-level signals, and system noise limits the resolution obtainable even on high-level ( $\pm 10$  V) signals. It is difficult to cool modules that have high power dissipation, and the shielding provided is not sufficient to isolate low-level cards completely from interference caused by high currents flowing in adjacent modules.

### Use in 9600 Systems

Model 2440A Analog-Digital Interface is the principal analog subsystem for HP 9600 Series Data Acquisition and Control Systems (see box, page 15). This subsystem, designated 9600 Option G00, contains the following plug-in modules (Fig. 3).

- A high-level ( $\pm 10$  V full scale) multiplexer, with a capacity of 16 differential or 32 single-ended signals, the choice being made by positioning jumpers on the card. Single-ended and differential channels may be mixed within a subsystem, but not within a module. This module receives its inputs from either the front connector or the

unguarded analog bus, and drives the guarded bus in a differential fashion.

- An interface to the HP 2930A programmable-gain low-level multiplexer. The HP 2930A has an input range of 10 mV to 10.24 volts programmable in 11 steps. This card can operate up to eight 2930A's (512 channels) and provide all necessary digital signals to the low-level multiplexers, whose analog outputs are interfaced to the 2440A through the high-level multiplexer card.
- A 12-bit analog-to-digital converter, which uses successive approximation at a 1 micro-second per bit rate for a total conversion time of 12 microseconds.
- A programmable pacer whose period may be varied from 1 microsecond to 2550 seconds under computer control. Provision is made for external starting or stopping of the pacer if it is desired to synchronize the pulse train to an external event. Another unusual feature is the ability to change the pace rate without losing synchronism with

## Unusual Pacer Excels in System Timing

Precise timing between measurements can be one of the more severe requirements faced by the designer of a computer-controlled system. In all but the simplest systems, timing must be under program control; hence it must be done either by software or by means of a programmable pulse generator of some type. The problem is that the accuracy of software timing is usually limited by the resolution of the computer's internal clock, and programmable pulse generators, while more accurate, tend to be costly and not designed specifically for systems use.

Systems (e.g., the 9600 Series) using Model 2440A Analog-Digital Interface as their analog front end have a unique timing capability in the form of a plug-in system pacer card. This card can supply timing pulses with more than 1800 discrete periods from one microsecond to 2550 seconds. The pulse period is programmable and accurate to  $\pm 0.01\%$ , and period-to-period variations (jitter) are less than 20 nanoseconds.

Unlike most pulse generators, the system pacer has the following features that are important for system timing: **Delayed or immediate start/stop and period change.** The first pace pulse can be issued immediately after the pacer is started, or it can be delayed one full pace period. Likewise, when told to stop, the pacer can do so immediately or issue one more pace pulse at the end of the current period. When changing periods, the change can be immediate, or delayed until the end of the current pace period as shown in the drawing. The change-delayed mode, which maintains synchronism with the previous pulse train, is useful when an accurate starting time reference is known and must be maintained.

**External start/stop.** An external start/stop line is provided for correlating the system's pacing with an external event. The pacer will start or stop within 350 nanoseconds  $\pm 150$  nanoseconds of the time of occurrence of the external signal at the pacer input connector.

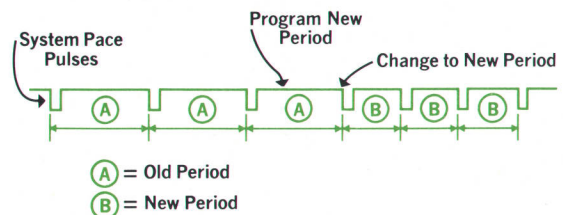

*Change-Delayed Mode Maintains Synchronism When Changing Periods*

**Pace error detection.** This important feature sets an information bit in the data word whenever one or more pace pulses have been missed by the system. Pace pulses can be missed if the computer is too busy servicing other peripherals to request a measurement from the 2440A. When this happens the 2440A will not respond to the pace pulse and time correlation of the measurements will be lost. Without the pace error bit it would be impossible to tell whether the 2440A had been serviced often enough by the computer. As a secondary benefit, the pace error feature may be used to determine maximum throughput rate experimentally (e.g., by increasing throughput until too many pace errors are detected). Maximum throughput rate is virtually impossible to predict theoretically.







also contributed a great deal by providing creative solutions to the systems problems encountered dur-

ing development. The digital-to-analog converter was designed by Wilson Wong.



### James M. Kasson

Jim Kasson heads HP's 9600 development section, which is responsible for developing dedicated and general-purpose 9600-Series systems. He was formerly project manager for the 2440A Analog-Digital Interface. Jim received his B. S. E. E. degree from Stanford University in 1964 and his M. S. E. E. degree from the University of Illinois in 1965. Before coming to HP in 1969 he was involved in speech bandwidth compression and speech recognition research. His interests range from computers and cybernetics on the professional side to population control, photography, and fine wines. For outdoor relaxation he favors bicycling and backpacking. Jim is a member of IEEE and the author of several articles in the electronics press.

## PARTIAL SPECIFICATIONS

### HP 9600 Series Options G00-G50

**DESCRIPTION:** A 12-bit, 45 kHz data acquisition subsystem based on the HP 2440A Analog-Digital Interface.

**RESOLUTION:** 12 bits, including sign—LSB = 5 mV.

**FULL-SCALE INPUT:** +10.235 V to -10.240 V.

**THROUGHPUT RATE TO BUFFER W/DMA<sup>1</sup>:**

To 45 kHz minimum.

**APERTURE TIME:** 50 ns, peak-to-peak time variation reading to reading, if paced by option G50 Programmable Pacer. Includes sample-and-hold aperture and pace pulse jitter.

**ACCURACY<sup>2</sup>:** (temperatures 10° to 40°C): 0.09% fs ±½ LSB (±0.05% fs is added by option G01; ±0.06% fs is added by option G02) ±0.0026% fs per °C; ±0.06% fs maximum drift in 30 days.

**NUMBER OF HIGH-LEVEL INPUTS:**

Per Opt. G10: 32 single-ended or 16 differential, jumper selectable.

In Opt. G00: Option G00 includes one option G10, can hold up to eight more of G10 for 288 single-ended/144 differential inputs total.

Opt. G01 & G02: Each of these options adds capacity for 12 additional option G10 multiplex cards; providing for 384 single-ended or 192 differential inputs. Options G00, G01, & G02 together can hold 1056 single-ended/528 differential inputs total.

Opt. G03: Last Address Detector card uses one high-level multiplexer card space.

Opt. G20: Low-level multiplexer interface card uses one high-level multiplexer card space. Two low-level multiplexer interface cards may be used in a single subsystem. Low-level option also uses one high-level multiplexer card.

**COMPUTER I/O CHANNEL:** One.

**LOW-LEVEL MULTIPLEXER:**

**RESOLUTION:** 12 bits, including sign.

**THROUGHPUT RATE TO BUFFER W/DMA<sup>1</sup>:** To 14.5 kHz, minimum.

**NUMBER OF INPUTS:** 8 to 64, added in eight-input increments.

Up to 512 inputs with one option G20 and seven option G21 multiplexers interfaced to G00. Up to 1024 inputs with two option G20 and 14 option G21 multiplexers interfaced to G00.

**ACCURACY** (of ADC and Low-Level Multiplexer, 10° to 40°C):

Range	±10.24 V	±10 mV
Overall (% fs) <sup>3</sup>	±0.18	±0.41
Temp. Coeff. (% fs/°C)	±0.005	±0.015
Long-Term Drift (30 days) (% fs)	±0.09	±0.31

**PLUG-IN PROGRAMMABLE PACER** (9600 Series Option G50):

**SAMPLE-SAMPLE TIMING:**

Interval Range: 1 μs to 2550 s in eight ranges.

Resolution: 1 μs to 10 s in eight steps.

**ACCURACY OF PACE INTERVAL:** Within ±0.01% of programmed interval.

**SUBSYSTEM APERTURE:** 50 ns, peak-to-peak time variation, reading to reading, for option G00 Subsystem paced by option G50 Programmable Pacer. (Pace intervals of 1 second or less.)

**EXTERNAL INPUT SIGNALS:** External Start/Stop and External Clock inputs.

**EXTERNAL OUTPUT SIGNALS:** Pace Pulse and Pace Gate outputs.

**PRICE IN USA:** Basic 9600 Systems with Opt. G00 start at \$21,000. Opt. G50 is \$1500.

**MANUFACTURING DIVISION:** AUTOMATIC MEASUREMENT DIVISION  
395 Page Mill Road  
Palo Alto, California 94306

<sup>1</sup>Assumes there are no interrupts from higher priority devices, no machine cycles used for Direct Memory Access transfer other than those servicing this subsystem, and no more than one level of indirect addressing.

<sup>2</sup>With respect to source used for calibration. Includes three sigma noise; linearity; offset; 8-hour stability gain, calibration transfer, and dynamic response errors; ±10% line voltage variation; and ±5°C temperature variation. Holds for source resistance ≤100 Ω.

<sup>3</sup>Holds for sample rates no greater than 200 samples per channel, option G00 Subsystem without expanders. Option G01 expander adds ±0.05% fs and option G02 adds ±0.06% fs to these accuracy figures.

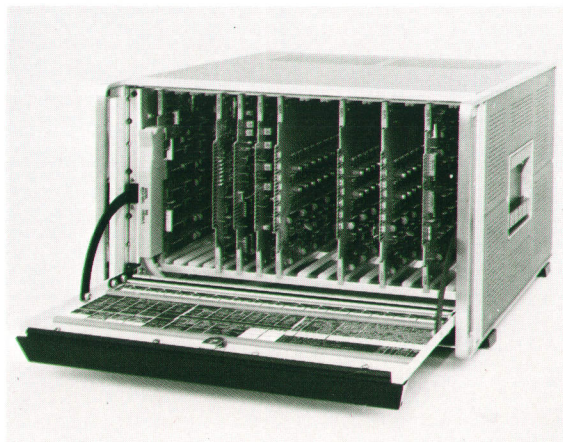



# Multiprogrammer Magnifies Minicomputer I/O Capacity

*When you have an automatic system with dozens or hundreds of devices to control and monitor, and only a minicomputer to do the job, this minicomputer I/O extender can help.*

**By John Mickowski**

**C**OMPUTERS USED AS CONTROLLERS in automatic systems frequently have to control and monitor large numbers of display panels, relays, power supplies, X-Y and chart recorders, switches, control valves, status indicators in the form of logic levels and contact closures, and other devices. In a system that requires a relatively small controller memory, or in a large system where a central computer supervises many smaller satellite controllers or data concentrators, the task of controlling and monitoring this multitude of devices usually falls to a minicomputer. However, a problem may arise because a minicomputer generally has a limited number of input/output channels, and the cost of adding extra channels may exceed the cost of the interfacing sensors, peripherals and software.

Model 6940A Multiprogrammer and Model 6941A Extender were designed to solve this problem reliably, efficiently, and at reasonable cost. These units expand a single 16-bit computer I/O channel into as many as 240 12-bit channels, each of which can control or monitor from one to twelve devices (see Fig. 1).

An earlier version of the Multiprogrammer, Model 6936A, was designed to replace the individually-designed interfaces needed for programming several analog power supplies. Its capabilities were subsequently expanded to include other test system control jobs, such as digital-to-analog-converter outputs, relay contact closures, logic-level outputs, and lamp drivers. The new 6940A Multiprogrammer (Fig. 2) has all of these analog and digital control functions, but it also provides for multiple digital inputs to the computer. It therefore closes the control and monitoring loop.

## Typical Applications

Potential applications for the new Multiprogrammer are numerous. Here is a basic list.

- Automatic test systems, e.g., for testing relays, integrated-circuit modules, semiconductors. Any test set requiring variable power sources, contact closures, digital-to-analog converters.
- Efficient (i.e. only one computer I/O slot) control of programmable instruments, such as the HP 1900A Pulse Generator system.
- Driving X-Y and chart recorders for process monitoring or display of electronic test results.
- Sensing events and monitoring status in large communication and automatic control systems by monitoring digital input lines.
- Digital data acquisition from remote locations, e.g., counting inventory or production line output, monitoring and controlling traffic signals.
- Direct digital control and monitoring in process-control systems.

Model 6940A Multiprogrammer is the principal digital subsystem in HP 9600-Series Data Acquisition and Control Systems (see box, page 15). It is also available as a separate product.

## Multiprogrammer Organization

The Multiprogrammer accepts up to 15 plug-in cards, each of which represents a 12-bit channel. As many as fifteen Model 6941A Extenders can be chained to one Multiprogrammer and each Extender accepts up to 15 additional cards. Thus as many as 240 12-bit channels can be operated from a single 16-bit computer I/O channel.

Among the many plug-in output cards for the Multiprogrammer there are resistance cards for pro-



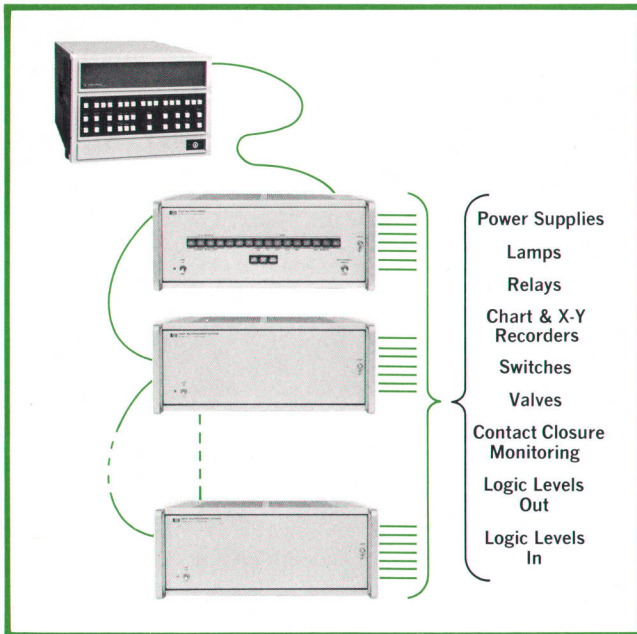

**Fig. 1.** Single 16-bit computer input/output channel expands to as many as 240 individually-addressable 12-bit channels with Model 6940A Multiprogrammer and chain of 6941A Multiprogrammer Extenders.

gramming power-supply voltage and current outputs, analog-to-digital converters that produce either voltage or current outputs, digital output cards, either mercury-wetted relays or solid-state, and a breadboard card that makes it possible for the user to design his own output circuits.

Input cards include those that accept digital inputs, either contact closures or logic levels. An event sense card compares a 12-bit input word with a computer-supplied reference word and generates an interrupt if the two words are equal, or are not equal, or if one is greater than the other, all depend-

ing on the position of a jumper. There is also a breadboard card for user-designed input circuits.

In addition, there is an accessory custom interface card that enables the Multiprogrammer to interface with other than TTL-logic-level computer I/O channels. Interfacing to Hewlett-Packard computers is straightforward with an Interface Kit (Model 14543A) that contains everything necessary to complete the hardware connection, and software to test and verify the interface.

### Multiprogrammer Operation

The Multiprogrammer uses a 16-bit-input, 16-bit-output word format for its interface with the computer (Fig. 3). The 16-bit input consists of four bits of address and 12 bits of data. The four address bits select which of 15 slots in the multiprogrammer is to receive the other 12 bits. In the case of an input function, the four address bits determine which slot will input data and transmit it to the computer. This combination of 16 bits is called a data word.

To control which box in a multi-unit chain of Multiprogrammers is exchanging data with the computer, a special code word called the control word is used. It is recognized by the Multiprogrammer when the four address bits are all 1's, corresponding to the decimal number 15. When the address 15 is detected, the remaining 12 data bits are interpreted by the Multiprogrammer as control information. This information includes the address of the unit in the chain which will receive subsequent data words, as well as bits to control other functions as follows:

Bits 0, 1, 2, 3. Unit Address. This selects which unit in a chain of up to 16 will receive the data words that follow.

Bit 4: Timing Mode Enable. When programmed to a

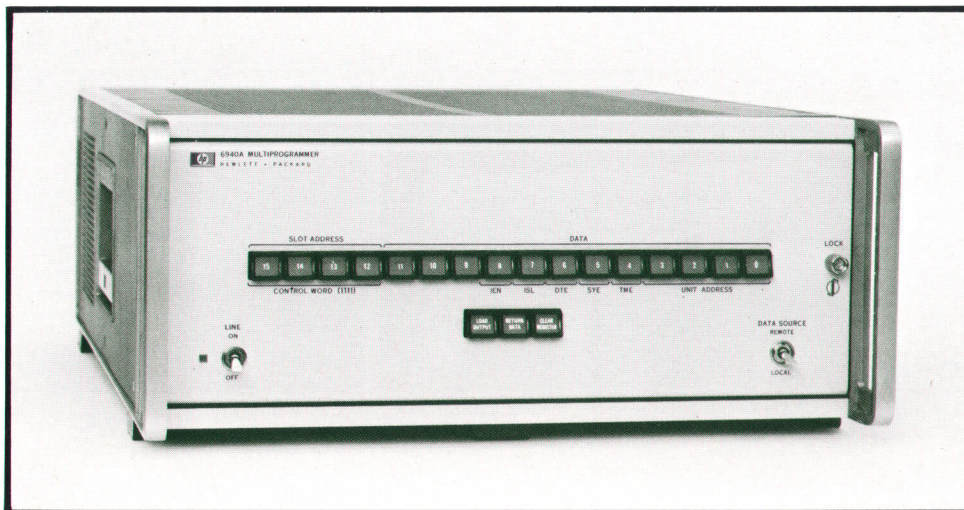

**Fig. 2.** Model 6940A Multiprogrammer has 15 I/O channels. During system set-up or troubleshooting, each channel can be controlled locally through proximity switches on front panel.



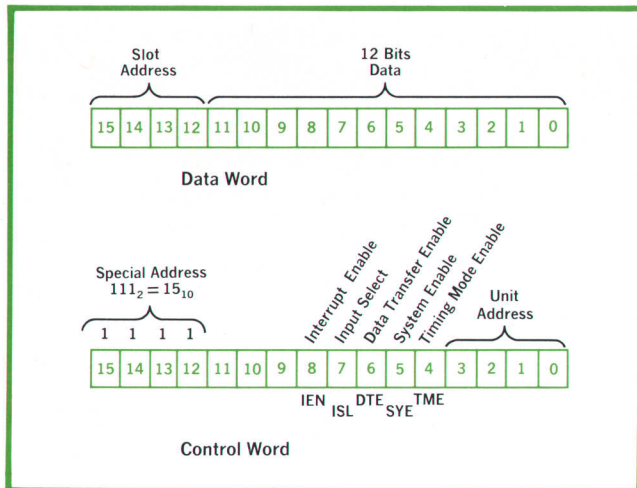

**Fig. 3.** Digital words used by Multiprogrammer. Each channel is addressed by bits 12–15 in data word. Remaining bits carry data. To control Extenders, control word with special address in bits 12–15 precedes data word. Bits 0–3 in control word select Extender to receive data words that follow.

logical zero, data is transferred to the Multiprogrammer at the maximum possible rate. When programmed to a logical one, the computer waits until the Multiprogrammer card has finished its operation before proceeding to program the next data transfer.

Bit 5: System Enable. This control line programs all outputs to a safe mode simultaneously if the system detects an emergency situation.

Bit 6: Data Transfer Enable. By programming this bit to a logical one, any predetermined combination of output cards, such as those needed to drive an X-Y display, will simultaneously update their output data.

Bit 7: Input Select. Selecting a one for this bit allows the addressed card to send 12 bits of input data to the computer. A zero indicates that the computer is sending 12 bits of data to a card.

Bit 8: Interrupt Enable. When this bit is set to a

logical one, cards that have interrupt capability and have been armed to generate interrupts are allowed to send interrupts to the computer.

To summarize, the control word sets up the state of the chain, and the data words exchange 12 bits of information between the computer and one card in the chain of units at a time.

### Reliable System Performance

Automatic systems represent substantial investments. The better they perform, and the more reliable they are, the greater is the return on that investment. The Multiprogrammer has been designed to enhance system performance and reliability as much as possible.

Features which enhance the dependability of the system are:

- Turn-on states for Multiprogrammer plug-in cards controlling digital outputs or power supplies are predetermined in hardware and correspond to safe modes of operation for the devices controlled.
- Digital data storage is included on all cards, to eliminate excess computer overhead.
- Outputs are programmed to the safe mode in case of power or computer failure.
- The computer ground is isolated from the output and power supply programming grounds.

Features which increase system performance are:

- Provision for simultaneous transfer of data from any combination of logic level outputs or high-speed analog outputs.
- Conversion of computer logic levels to other levels required in the system.
- Ability to select data transfer timing between the computer and the Multiprogrammer either to proceed at the maximum possible rate, or to be governed by the settling time of the particular device being controlled by each output instruction.

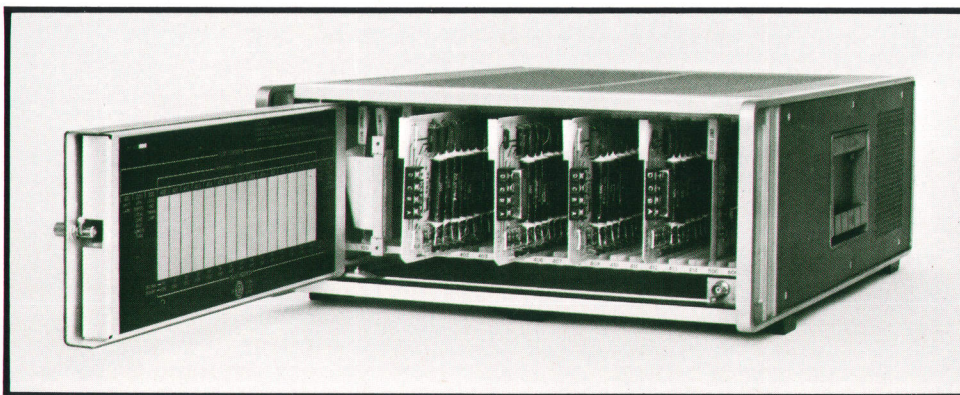

**Fig. 4.** Model 6940A accepts up to 15 input and output cards (four shown here partially inserted) in any combination. Cards are easily added, removed, or interchanged to modify capabilities of data acquisition and control system.



Particular attention has been paid to reliability in the design of the instrument, and the packaging promotes quick diagnosis of system failures and servicing of all modules. All plug-in cards are accessible through the front panel, via a door which extends the full width of the instrument (Fig. 4). A switch register on the front panel permits local, manual control of all card slots in a Multiprogrammer. This is especially useful in setting up or troubleshooting a system since in many instances, setup or troubleshooting is much easier under manual control than with special software to accomplish system diagnosis. When the Multiprogrammer is under computer control, the manual switch register is locked out of control of the system, and the lights behind the switches indicate the status of the data lines in the Multiprogrammer.

### Expandability

Because system requirements often grow, the ideal system component must be easily expandable. Expansion of a system of Multiprogrammers usually is accomplished with no changes in the computer I/O hardware, since only one interface is necessary for a Multiprogrammer and up to 15 Extenders. If system demands ever exceed the capabilities of 240 plug-in cards, one additional computer I/O channel will double the Multiprogrammer input/output capacity.

### Correction

The article 'New Capabilities in Digital Low-Frequency Spectrum Analysis,' (*Hewlett-Packard Journal*, June 1972) stated that in a speed-up analyzer "there's a 20-to-100 millisecond gap between the processing of one T-second record and the next, so some of the signal information is lost." Speed-up analyzers do not exhibit any such gap. The gap that the authors intended to describe was the 20-to-100 ms time span between analysis of the first and last frequencies in a data block, which could have an effect on results obtained with nonstationary signals, or random signals in which there is significant correlation between frequencies.

Speed-up analyzers load a sampled and digitized waveform into a shift register and circulate it at a high rate. Simultaneously, the circulating information is converted back to analog form, essentially translating the original waveform spectrum to a higher frequency band. Analysis of the new spectrum with a bandpass filter requires one complete circulation of the data for each frequency. Normally the instrument drops the oldest sample and adds a new one each time the data circulates. This means the data block changes continuously and, if the signal is nonstationary, the frequency coefficients will not be determined on identical blocks of data.

### Acknowledgments

Industrial design of the new Multiprogrammer, including thermal engineering, was by John Pratt. Many thanks are due Earl Gable, for his conscientious, enthusiastic performance as technician and general expeditor, Brett Nordgren for general guidance and contributions from his systems expertise, and Joseph Skowronski and Robert Willmot for invaluable help in defining the product. 



### John Mickowski

Recognizing the multidisciplinary character of today's technology, John Mickowski added an MSEE degree to the BSME degree that he had earned in 1967 at the Stevens Institute of Technology. He's a member of both the Society of Automotive Engineers and Tau Beta Pi.

John's professional career began in 1967 measuring the performance of experimental aircraft engines. Then he went 100% electronic, joining Hewlett-Packard as an electronic engineer working on digitally-controlled voltage sources. Later he became project leader on the Model 6936A Multiprogrammer which ultimately led to the Model 6940A.

On completion of the 6940A project, he elected to take a 6-month leave of absence from his post as group leader of the Programmable Instrument Group to explore some ideas unrelated to his work at HP.

John continues to design and build engines as a hobby and also conjures up electromechanical gadgets. But then he also likes to paint in oils, play squash, and go motorcycling.



## SPECIFICATIONS

### HP Model 6940A Multiprogrammer

### HP Model 6941A Extender

**FRONT-PANEL CONTROLS (6940A):** Power ON/OFF switch and indicator lamp, REMOTE/LOCAL switch for selecting computer or manual control, 19 proximity switches for manual data entry and control.

**FRONT-PANEL CONTROLS (6941A):** Power ON/OFF switch and indicator lamp.

**INTERFACING:** 6940A mainframe equipped with standard interface card interfaces with binary sources employing TTL or DTL micro-circuit logic. Kit (14543A) containing necessary hardware and software to interface with any HP computer is available. Optional custom interface card (69340A) is also available to satisfy customer requirements different from those of standard card.

**INPUT/OUTPUT CARD POSITIONS:** Maximum of 15 plug-in input or output cards per mainframe.

**MAINFRAME DATA CONNECTORS:** Two 50-contact, rear-mounted, female ribbon connectors.

**DATA TRANSFER RATE:** 100k word/s guaranteed minimum (measured at mainframe data connector).

**MAXIMUM DATA RESOLUTION:** 12 bits.

**COOLING:** Natural convection.

**TEMPERATURE RANGE:** 0 to +55°C operating, -40 to +75°C storage.

**WEIGHT (6940A):** 35.0 lbs (15,9 kg).

**WEIGHT (6941A):** 33.5 lbs (15,2 kg).

**DIMENSIONS:** 16¾ W x 6¾ H x 21¼ D (43,54 x 17,22 x 53,98 cm).

### OUTPUT CARDS

**SERIES ELEMENT OUTPUT CARD, Model 69300A:**

Allows customer to select and load own series-adding elements, such as resistors.

**OUTPUT CHANNELS:** One 12-element or two independent 6-element.

**PARALLEL ELEMENT OUTPUT CARD, Model 69360A:**

Allows customer to select and load own parallel-adding elements, such as capacitors.

**OUTPUT CHANNELS:** One 12-element or two independent 6-element.

**POWER SUPPLY PROGRAMMING CARDS, Models 69301A-69313A:**

Supplies resistance for programming voltage and current outputs of HP power supplies equipped with Option 040.

**OUTPUT CHANNELS:** Models 69301A-69304A, one 12-element channel for programming output voltage of one power supply. Models 69310A-69313A, two independent 6-element channels for programming output current of two power supplies.

**VOLTAGE D/A CONVERTER CARD, Model 69321A:**

Provides high-speed bipolar output voltage that is analog of digital input to card. (69351A voltage regulator also required.)

**OUTPUT:** -10.240 to +10.235 Vdc, at 0-5 mA.

**RESOLUTION:** 5 mVdc.

**ACCURACY:** ±2.5 mVdc at 25°C ±5°C.

**PROGRAMMING SPEED:** 50 μs max to within 5 mV of final value.

**CURRENT D/A CONVERTER CARD, Model 69370A:**

Provides high-speed constant-current output that is analog of digital input to card. (69351A voltage regulator required.)

**OUTPUT:** 0 to +24.470 mA, at 0-11 Vdc.

**RESOLUTION:** 10 μA.

**ACCURACY:** ±5 μA at 25°C ±10°C.

**PROGRAMMING SPEED:** 100 μs max to within 10 μA of final value.

**RELAY REGISTER CARD, Model 69330A:**

Provides 12 independent SPST normally-open contact pairs.  
**CONTACT RATINGS:** 100 Vdc, 100 Vrms, 1.0 A switching, 28 W max.

**PULL-IN TIME:** 3.5 ms max.

**RELEASE TIME:** 1.0 ms max.

**RELAY OUTPUT/READBAC CARD, Model 69433A:**

Similar to 69330 Relay Register Card, except has readback (output data verification) capability.

**TTL OUTPUT CARD, Model 69331A:**

Provides 12 bits with TTL/DTL compatible logic levels.

**OUTPUT LEVELS:** Standard: LOW=0 to +0.3 Vdc (sink 32 mA max); HIGH=+4.5 to +5.0 Vdc (1k source impedance). Option 073: positive true 5 Vdc logic levels. User-selectable option: 0 to +12 Vdc (nominal) logic levels or open-collector drivers.

**BREADBOARD OUTPUT CARD, Model 69380A:**

Allows customer to design and build own analog or digital output circuit.

### INPUT CARDS

**DIGITAL INPUT CARD, Model 69431A:**

Monitors 12 lines of TTL, DTL, RTL, or contact closure logic. All lines referenced to computer common.

**INPUT LEVELS:** Option 069, ground true 5 Vdc logic; Option 070, ground true 12 Vdc logic or contact closures; Option 073, positive true 5 Vdc logic.

**ISOLATED DIGITAL INPUT CARD, Model 69430A:**

Monitors 12 independent 12 V inputs. All input lines are isolated.

**EVENT SENSE/INTERRUPT INPUT CARD, Model 69434A:**

Compares 12 bits of digital input data (contact closure logic) with 12 bits of reference data stored on card, and generates an interrupt signal when certain conditions are met.

**BREADBOARD INPUT CARD, Model 69480A:**

Allows customer to design and build own analog or digital input circuit.

### ACCESSORIES

**CUSTOM INTERFACE CARD, Model 69340A:**

Permits interfacing 6940A with external programming sources having logic-level, logic-sense, or termination specifications different from those of standard interface card.

**INPUT LEVELS:** Option 070, ground true 12 Vdc logic levels; Option 071, positive true 5 Vdc logic levels; Option 072, Special Interface Card (allows customer to select and install own termination networks).

**6940A INTERFACE KIT, Model 14543A:**

Contains necessary hardware and software to interface 6940A with any HP computer, and to verify system operation.

**CHAINING CABLE ASSEMBLY, Model 14541A:**

Connects 6940A mainframes to 6941A mainframes, and 6941A's to other 6941A's.

**LENGTH:** 18 inches.

**VOLTAGE REGULATOR CARD, Model 69351A:**

One required in every mainframe containing 69321A

Voltage or 69370A Current D/A Converter Cards.

**PRICES IN USA:**

6940A Multiprogrammer mainframe: \$1500.

6941A Extender mainframe: \$900

14541A Chaining Cable Assembly: \$150.

14543A Interface Kit: \$1250.

Input and output cards range from \$200 to \$450.

Breadboard cards are \$75.

**MANUFACTURING DIVISION: NEW JERSEY DIVISION**

Green Pond Road

Rockaway, New Jersey 07866

**HEWLETT-PACKARD JOURNAL**  
AUGUST 1972 Volume 23 • Number 12



*Technical Information from the Laboratories of  
Hewlett-Packard Company, 1501 Page Mill Road,  
Palo Alto, California 94304 U. S. A.*

*Hewlett-Packard S. A., 1217 Meyrin—Geneva, Switzerland  
Yokogawa-Hewlett-Packard Ltd., Shibuya-Ku, Tokyo 151 Japan*

*Editorial Director: Howard L. Roberts*

*Managing Editor: Richard P. Dolan*

*Contributing Editors: Ross H. Snyder, Laurence D. Shergalis*

*Art Director, Photographer: Arvid A. Danielson*

*Art Assistant: Erica R. Helstrom*

*Administrative Services: Ruth G. Palmer*